

Addendum Number 3

Project: Cone Center HVAC Modernization
The University of North Carolina at Charlotte
SCO Project # SCO #16-12981-01

Date: July 19, 2017

Owner: The University of North Carolina at Charlotte

Designer: McCracken & Lopez, PA

NOTICE TO BIDDERS

This addendum is issued prior to receipt of bids, proposals, and its contents do hereby become a part of the pricing documents for the above referenced project.

All trade contractor bidders are responsible for assuring that their subcontractors and vendors are properly apprised of the contents of this Addendum.

All information contained in this Addendum supersedes and takes precedence over any conflicting information in the original pricing documents.

All bidders must acknowledge receipt of this Addendum in the space provided on the Form of Proposal for their bid package.

GENERAL INFORMATION

The bid date is Wednesday, July 26, 2017 at 2:00 PM, as indicated in Addendum 1. The location is Room 112 in the Cone Building at UNC Charlotte.

Bidders who will not attend the Bid Opening need to ensure their sealed bids are delivered **no later than 1:00 PM, Wednesday, July 26, 2017** to the address indicated on page 3 of reissued Section 00 21 19 "Notice to Bidders" (Addendum 1).

ATTACHMENTS

This Addendum includes the following attached Drawings:

1. M004 – Motor Control Schedule & HVAC Roof Plan (Revision 1)

DRAWING Clarifications and Revisions

Refer to the following attached revised drawings for changes, per Revision 1, dated 7-19-17:

1. M004 – Motor Control Schedule & HVAC Roof Plan (Revision 1) (REISSUED DRAWING)

SPECIFICATION Clarifications and Revisions

Section 23 00 10 – General Provisions - Mechanical

1. On page 18, table for Paragraph 2.5.A, for Section 23 09 00 “Building Automation System,” delete reference to “Siemens (BACNET),” “Trane (BACNET,” and “Schneider Electric (BACNET),” and replace with the following:

“Refer to Section 23 09 00, paragraph 1.11.D for UNCC List of Acceptable Contractor’s.”

NOTE: ECS is being added to this list by Addendum 3.

Section 23 09 00 – Facility Management and Control System

1. On page 9, table for Paragraph 1.11.D, add the following manufacturer to UNCC’s List of Acceptable Contractors:

“6. ECS (Engineered Control Systems)”

BIDDER QUESTIONS FROM WALK-THRU

Question/Comment 1: Control clarification on t-stat new work note reading "Tridium compatible." What is the intent?

ML Response: VAV controllers to be BACnet type, open protocol with digital display face adjustable t-stats. All integrated back to the Tridium front end.

Question/Comment 2: Will the new switchgear and existing generator be integrated into the BAS?

ML Response: Integration with new gear and generator is not a part of this project per UNCC.

Question/Comment 3: Will existing VAV controllers be reused or can we replace with new to match?

ML Response: Remove all controllers on VAV units (DDC and pneumatic alike) and replace with new, all by same manufacturer.

Question/Comment 4: Add 120V power source for controls.

ML Response: Electrical sub-contractor to provide one 15A 120V circuit to J-box above ceiling centrally in areas of work for control power. Coordinate location with MC.

Question/Comment 5: Schedule is tight, is there any flexibility?

ML Response: The University is open to some limited flexibility in the schedules, however this will be discussed after notice to proceed.

Question/Comment 6: Two fans on 2nd floor have chilled water.

ML Response: Remove pipe back to main valves and cap. Remove fan units.

Question/Comment 7: Will furniture be removed by University?

ML Response: Yes. The University will have this removed from each space as needed.

Question/Comment 8: Wireless on towers and control conduits.

ML Response: Per UNCC, no. Reuse existing conduits if at all possible. Provide new 1.5" conduit from chiller room to cooling tower yard as a unit price.

Question/Comment 9: Will Ventures area be full work?

ML Response: No. Scope in Ventures area (lower level north of mechanical air-handling room below auditorium) will be minimal. Replace diffusers, replace VAV unit and t-stat, rebalance VAV unit. No ceiling tile replacement - as was originally specified on drawings. Drawing M801 will be re-issued at a later date.

BIDDER PRE-BID RFI'S/QUESTIONS

Question 1: Subj: New Ceiling Grid & Ceiling Tile Specifications. Please direct to these specifications if included in the bid manual or provide if they weren't.

ML Response: Armstrong 770 Cortega Minaboard, 24" x 24" size; Color – White; Edge – Square Edge; Grid Face – 15/16"; Contents – Mineral Board.

Question 2: Subj: Duct Cleaning & Re-Sealing. Is duct cleaning required for newly installed ductwork and/or new VAV boxes?

ML Response: No.

Question 3: Subj: Duct Cleaning & Re-Sealing. Is cleaning required for existing to remain VAV boxes?

ML Response: No.

Question 4: Subj: Duct Cleaning & Re-Sealing. What are the requirements for cleaning, re-sealing, re-insulating ductwork in inaccessible areas such as chases?

ML Response: Not required in inaccessible areas.

Question 5: Subj: Duct Cleaning & Re-Sealing. Leakage testing after re-sealing ductwork is only mentioned on drawing DM301 for mechanical room 230. Is this required? Is leakage testing required for re-sealed existing ductwork in other areas?

ML Response: Yes.

Question 6: Subj: Duct Cleaning & Re-Sealing. Is the only ductwork to be cleaned, re-sealed and tested associated with AHU5 – the existing duct to remain in mechanical room?

ML Response: Yes. Do not do McKnight Hall.

Question 7: Subj: Duct Cleaning & Re-Sealing. Is the intention for all existing ductwork associated with AHU-4 to be cleaned and re-sealed? Note 2 on M102 ~~DM102~~ for the 3rd floor mentions the 1st and 2nd floor only. Please clarify.

ML Response: This is only to be done in McKnight Hall Lobby.

Question 8: Subj: Fire Alarm. Please provide contact information for the Simplex representative that handles UNC Charlotte's account.

ML Response: Jonathon Layne / jolayne@simplexgrinnell.com OR
Martin Driscoll / madriscoll@simplexgrinnell.com

Question 9: Subj: Phase Durations.

Is there flexibility in the phasing dates, time span within each phase, substantial completion date and associated liquidated damages?

ML Response: Yes. We acknowledge the concerns and offer the following:

- 1) Schedule discussion should take place immediately after notice to proceed with final schedule to be agreed upon within 30 calendar days after notice to proceed.
- 2) Work outside of occupied spaced can begin immediately after the Notice to Proceed.
- 3) Individual occupied space completion dates (i.e., Floors 1-3) are flexible within 2-3 weeks, however ceiling work must be complete and systems operating for beneficial use by the University, under local control, by December 31st in all areas.
- 4) AHU-4 and cooling towers cannot be shut down for an extended duration until the dates listed.
- 5) Cooling tower replacement can occur separately in January or over a weekend, pending approval on final dates by UNCC.

Would it be possible to remove the liquidated damages requirement?

ML Response: The final schedule will be coordinated with the University and low bid contractor. Liquidated damages will be enforced on Floor 1 & 2 only (beneficial use date to be negotiated) and on AHU-4 beneficial use date of December 31st as the Owner will incur additional costs for temporary services and relocation.

Would the University consider an open discussion for coordination of phasing and durations in order to complete the project?

ML Response: Yes. This scheduling activity must be complete within 30 days of notice to proceed. Refer to items above for important dates to the University.

Bid time extension:

ML Response: No. The original bid date was already extended 3 weeks. To meet the dates, we will need to keep the scheduled bid dates.

End of Addendum 3

MOTOR CONTROL SCHEDULE														
MOTOR DESIGNATION	UNIT USE	POWER SOURCE	RATING			MOTOR STARTER				AUXILIARY CONTROL DEVICES				
			HORSEPOWER (KW)	VOLTAJE	PHASE	MOTOR LOCATION	TYPE	LOCATION	FURNISHED BY	INSTALLED BY	ITEM	LOCATION	FURNISHED BY	INSTALLED BY
AHU-4	SUPPLY FAN	NORMAL	40	480	3	AT UNIT	VFD	AT UNIT	MC	EC	DDC CONTROLLER	AT UNIT	MC	MC
RAF-4	RETURN FAN	NORMAL	5	480	3	AT UNIT	VFD	RM 230 WALL	MC	EC	SMOKE DETECTOR	RA DUCT	EC	MC
AHU-5	SUPPLY FAN	NORMAL	10	480	3	AT UNIT	VFD	AT UNIT	MC	EC	RELAY	-	MC	MC
EF-2	EXHAUST FAN	NORMAL	1/3	120	1	AT UNIT	FVNR	AT UNIT	EC	EC	DDC CONTROLLER	AT UNIT	MC	MC
EF-3	EXHAUST FAN	NORMAL	1/6	120	1	AT UNIT	FVNR	AT UNIT	EC	EC	SMOKE DETECTOR	RA DUCT	EC	MC
CT-1	COOLING TOWER FAN	NORMAL	5	480	3	COOLING TOWER ENCLOSURE	VFD	RM 230 WALL	MC	MC	ELEC. BASIN HEATER THERMOSTAT	IN BASIN	MC	MC
	BASIN HEATER	NORMAL	2Ø (6 kW)	208	3	AT UNIT			MC	MC	VIBRATION SWITCH	TOP OF TOWER	MC	MC
CT-2	COOLING TOWER FAN	NORMAL	5	480	3	COOLING TOWER ENCLOSURE	VFD	RM 230 WALL	MC	MC	ELEC. BASIN HEATER THERMOSTAT	IN BASIN	MC	MC
	BASIN HEATER	NORMAL	2Ø (6 kW)	208	3	AT UNIT			MC	MC	VIBRATION SWITCH	TOP OF TOWER	MC	MC

MOTOR CONTROL SCHEDULE NOTES

MOTOR CONTROL SCHEDULE ABBREVIATIONS:

- ALT ALTERNATOR
- AUX AUXILIARY CONTACTS
- EC ELECTRICAL CONTRACTOR
- FACP FIRE ALARM CONTROL PANEL
- FPC FIRE PROTECTION CONTRACTOR
- FVNR FULL VOLTAGE NON-REVERSING - MAGNETIC STARTER WITH FUSED DISCONNECT SWITCH
- MC HVAC CONTRACTOR
- MCCC MOTOR CONTROL CENTER
- PC PLUMBING CONTRACTOR
- RVNR REDUCED VOLTAGE NON-REVERSING MAGNETIC STARTER
- VFD VARIABLE FREQUENCY DRIVE WITH DISCONNECT SWITCH

MOTOR CONTROL SCHEDULE NOTES:

- A. REFER TO SECTION 260126 FOR DESCRIPTION OF DIVISION OF ELECTRICAL WORK BETWEEN DIVISION 23 AND 26. THE MECHANICAL CONTRACTOR SHALL PROVIDE EACH PIECE OF EQUIPMENT REQUIRING POWER CONNECTIONS WITH LUGS SUITABLE FOR THE CABLES BEING PROVIDED.
- B. SWITCHES AND STARTERS EXPOSED TO THE WEATHER SHALL BE SUITABLE FOR INSTALLATION OUTDOORS.
- C. FUSE EACH STARTER WITH NEMA R-K1 TIME DELAY, DUAL ELEMENT, CURRENT LIMITING FUSES AT 150% OF MOTOR FULL LOAD AMPERE RATING OR NEXT UP STANDARD FUSE SIZE.
- D. MOTOR CONTROLLERS (STARTERS) SHALL HAVE ENCLOSURES SUITABLE FOR ENVIRONMENT AT THEIR LOCATION. USE NEMA 3R TYPE ENCLOSURES FOR OUTDOOR INSTALLATIONS, AND NEMA 12 ENCLOSURES FOR EQUIPMENT IN AIR PLENUM.

- 1. THE ABOVE LISTED SCHEDULE OUTLINES THE MAJOR MOTOR LOADS, STARTERS AND THEIR ASSOCIATED AUXILIARY CONTROL DEVICES. IN NO CASE IS THIS SCHEDULE MEANT TO ONLY INDICATE ALL DEVICES, BUT TO ASSIST THE DIVISION 23 CONTRACTORS IN CLARIFYING THEIR SCOPE OF WORK. UNIT HEATERS, ETC. MISCELLANEOUS MOTORS MAY NOT BE REPRESENTED. ALL STARTERS SHALL BE SIZED FOR PROPER OPERATION AND IN CASES WHERE MC WIRES A DEVICE, WIRING AND CONDUIT SHALL BE SIZED PER LATEST EDITION OF N.E.C. IN ACCORDANCE WITH METHODS AND REQUIREMENTS STATED IN DIVISION 26 - ELECTRICAL CONTRACT DOCUMENTS.
- 2. IN THE FACP THE ELECTRICAL CONTRACTOR SHALL SUPPLY ONE NORMALLY OPEN AND ONE NORMALLY CLOSED CONTACT FOR EACH AHU SYSTEM. THE ELECTRICAL CONTRACTOR WILL PROVIDE 5/14 WIRES FOR THESE CONTACTS TO THE AHU SYSTEM CONTROL PANEL FOR TERMINATION BY THE MECHANICAL CONTRACTOR. ALL ADDITIONAL CONTACTS, WIRING AND RELAYS SHALL BE PROVIDED BY THE MECHANICAL CONTRACTOR.
- 3. STARTER TYPE (PROVIDED BY MC)
 - A. (FVNR) (INTEGRAL WITH UNIT) FULL VOLTAGE, NON-REVERSIBLE MAGNETIC STARTERS FURNISHED AS PART OF THE UNIT AND FUSIBLE SWITCH OR EQUIVALENT AS ACCEPTED BY A-E. WIRING FROM STARTER TO MOTOR SHALL BE PROVIDED BY EQUIPMENT MANUFACTURER.
 - B. (FVNR) (NOT INTEGRAL WITH UNIT) COMBINATION FULL VOLTAGE NON-REVERSIBLE MAGNETIC STARTER WITH DISCONNECT SWITCH. WIRING FOR STARTER TO MOTOR SHALL BE PROVIDED BY HVAC CONTRACTOR.
 - C. (VFD) VARIABLE FREQUENCY DRIVE SHALL HAVE INTERNAL INCOMING LINE POWER DISCONNECT SWITCH THAT SHALL CUT POWER TO ENTIRE UNIT WHEN IN OPEN POSITION. WIRING FROM VFD TO EQUIPMENT MOTOR SHALL BE PROVIDED BY HVAC CONTRACTOR.

EXCEPTION: FOR THIS PROJECT, THE WIRING FROM THE CT-1 AND CT-2 VFDs IN MECHANICAL ROOM 230 TO THE DISCONNECTS AT THE COOLING TOWERS SHALL BE BY THE ELECTRICAL CONTRACTOR DUE TO THE WIRING DISTANCE AND COMPLEXITY OF THE WIRING INSTALLATION. THE COOLING TOWER DISCONNECTS AT THE TOWER ENCLOSURE SHALL BE BY DIVISION 26. DIVISION 23 SHALL WIRE FROM THESE DISCONNECTS TO THE TWO COOLING TOWERS.

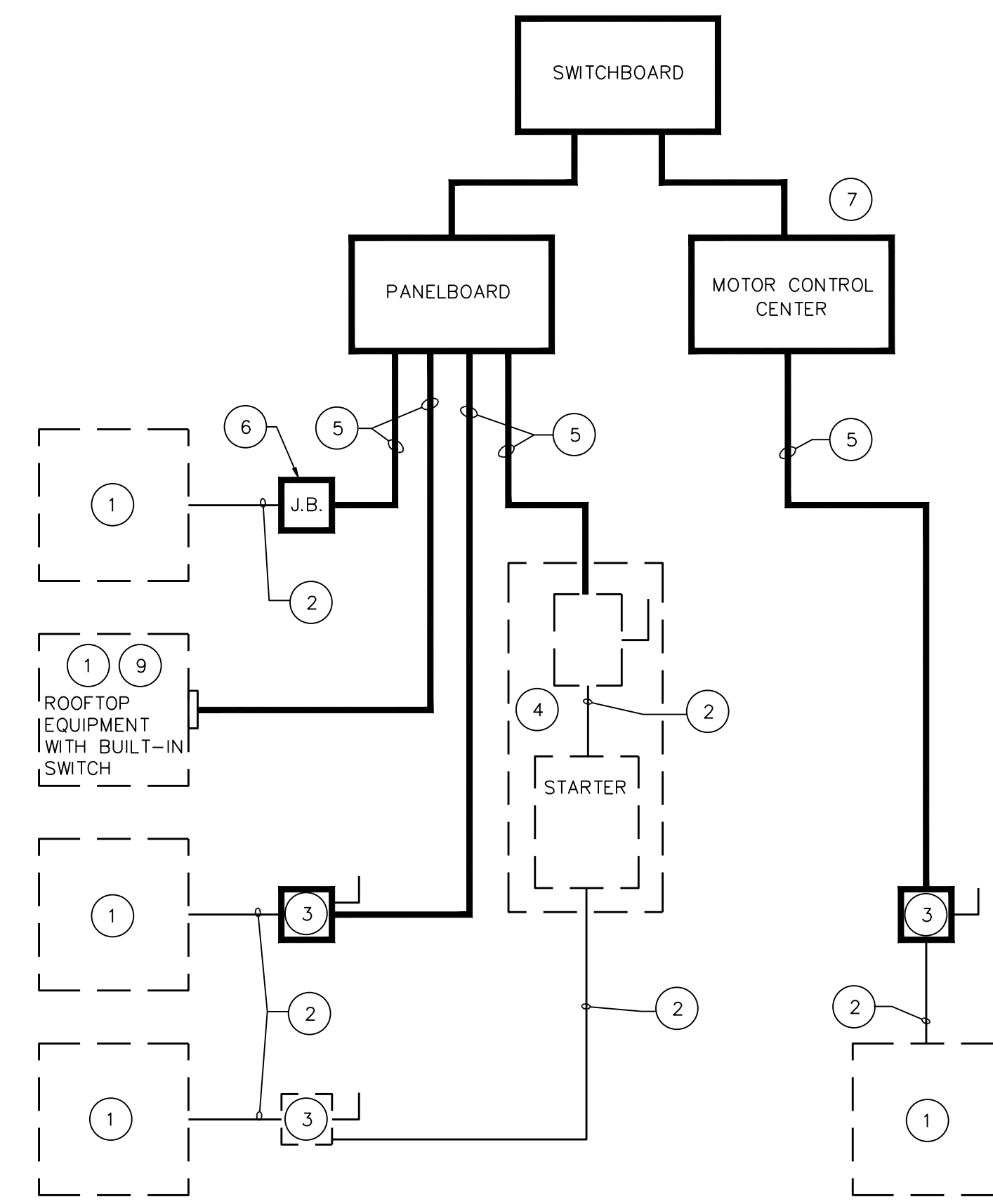

2 ELECTRICAL EQUIPMENT CONNECTION DIAGRAM

NOTE: THIS DIAGRAM IS INTENDED TO REPRESENT THE DIVISION OF WORK BETWEEN DIVISION 26 AND DIVISIONS 21, 22 AND 23, IN ACCORDANCE WITH THE REQUIREMENTS OF SECTION 260120.

ELECTRICAL NOTES AND LEGEND:

- 1 HVAC, FIRE PROTECTION ("FP") OR PLUMBING EQUIPMENT, AS APPLICABLE.
- 2 CONDUIT & WIRING BY HVAC, FP OR PLUMBING CONTRACTOR.
- 3 IF AN ADDITIONAL DISCONNECT IS REQUIRED BY NEC IT SHALL BE PROVIDED AND INSTALLED BY DIVISION 22 OR 23 CONTRACTOR, AS APPLICABLE.
- 4 A COMBINATION STARTER OR VFD MAY BE USED IN LIEU OF A SEPARATE DISCONNECT AND STARTER. LOCATE ADJACENT TO EQUIPMENT.
- 5 FEEDER CIRCUIT WIRING AND CONDUIT IN ELECTRICAL WORK. SEE PANELBOARD SCHEDULES FOR WIRE AND BREAKER SIZES.
- 6 JUNCTION BOX MAY BE SHOWN ON ELECTRICAL PLANS FOR SOME EQUIPMENT IF NO STARTER OR DISCONNECT IS SUPPLIED. A JUNCTION BOX SHALL BE INSTALLED ADJACENT TO EQUIPMENT. THE ELECTRICAL CONTRACTOR SHALL PROVIDE LINE SIDE WIRING TO THE JUNCTION BOX. LOAD SIDE WIRING WILL BE PROVIDED BY HVAC, FP OR PLUMBING CONTRACTOR, AS APPLICABLE.
- 7 PROJECTS UTILIZING AN MCC, THE STARTER, CB, OR VFD IN THE MCC ARE PROVIDED BY THE ELECTRICAL CONTRACTOR.
- 8 IN ALL CASES THE CONTRACTOR PROVIDING THE EQUIPMENT SHALL MAKE FINAL CONNECTIONS, START UP, AND TEST EQUIPMENT.
- 9 IF THE ROOF TOP EQUIPMENT IS NOT PROVIDED WITH BUILT-IN SWITCH, THE ELECTRICAL CONTRACTOR SHALL PROVIDE A DISCONNECT SWITCH.
- 10 POWER WIRING BETWEEN DIVISION 23 VFD CONTROLLER AND MOTOR SHALL BE PROVIDED UNDER DIVISION 23 AND IT SHALL CONSIST OF 3-PHASE, 3-GROUND, COPPER TAPE SPIRAL SHIELD, GALVANIZED STEEL INTERLOCKED ARMOR CABLE RUN IN CONDUIT TO ENSURE SYSTEM RELIABILITY. THE CABLE SHALL BE TERMINATED IN CONNECTOR DESIGNED EXCLUSIVELY FOR ASD/VFD CABLE. THIS CABLE SHALL BE RUN IN CONDUIT.
- 11 FINAL CONNECTION TO DIVISION 21, 22 OR 23 EQUIPMENT, AS APPLICABLE, SHALL BE PROVIDED BY THE CONTRACTOR FURNISHING THE EQUIPMENT.

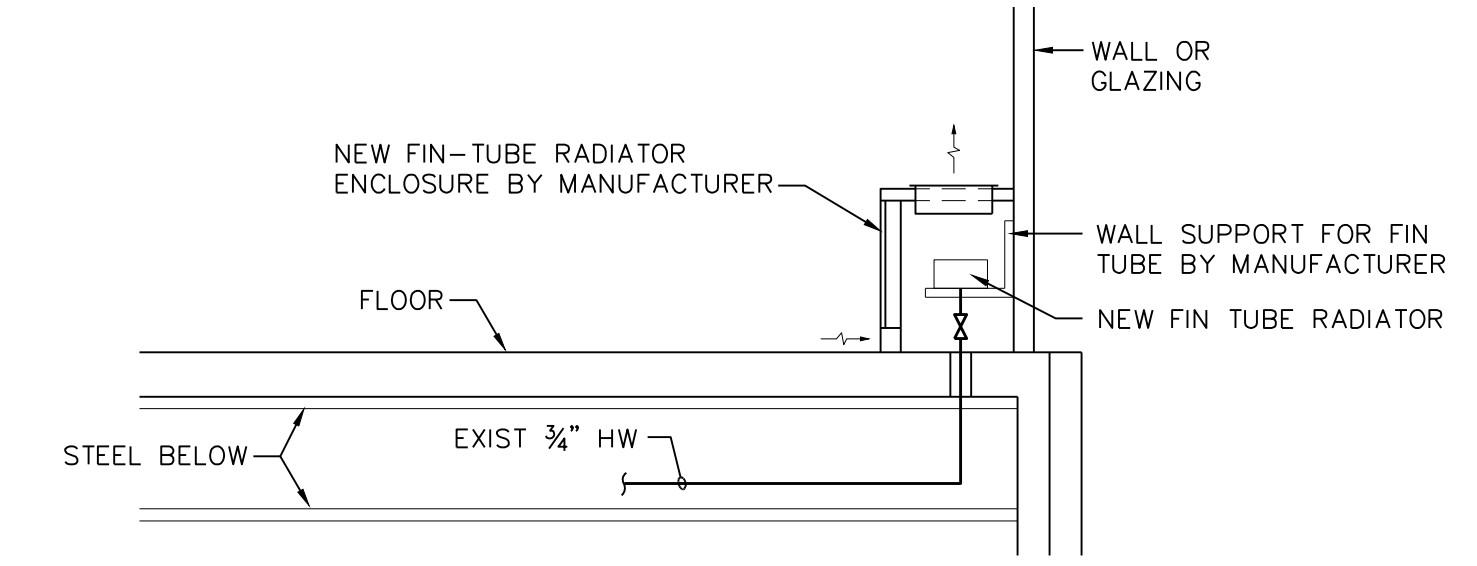

3 FIN TUBE RADIATOR DETAIL

SCALE: NONE

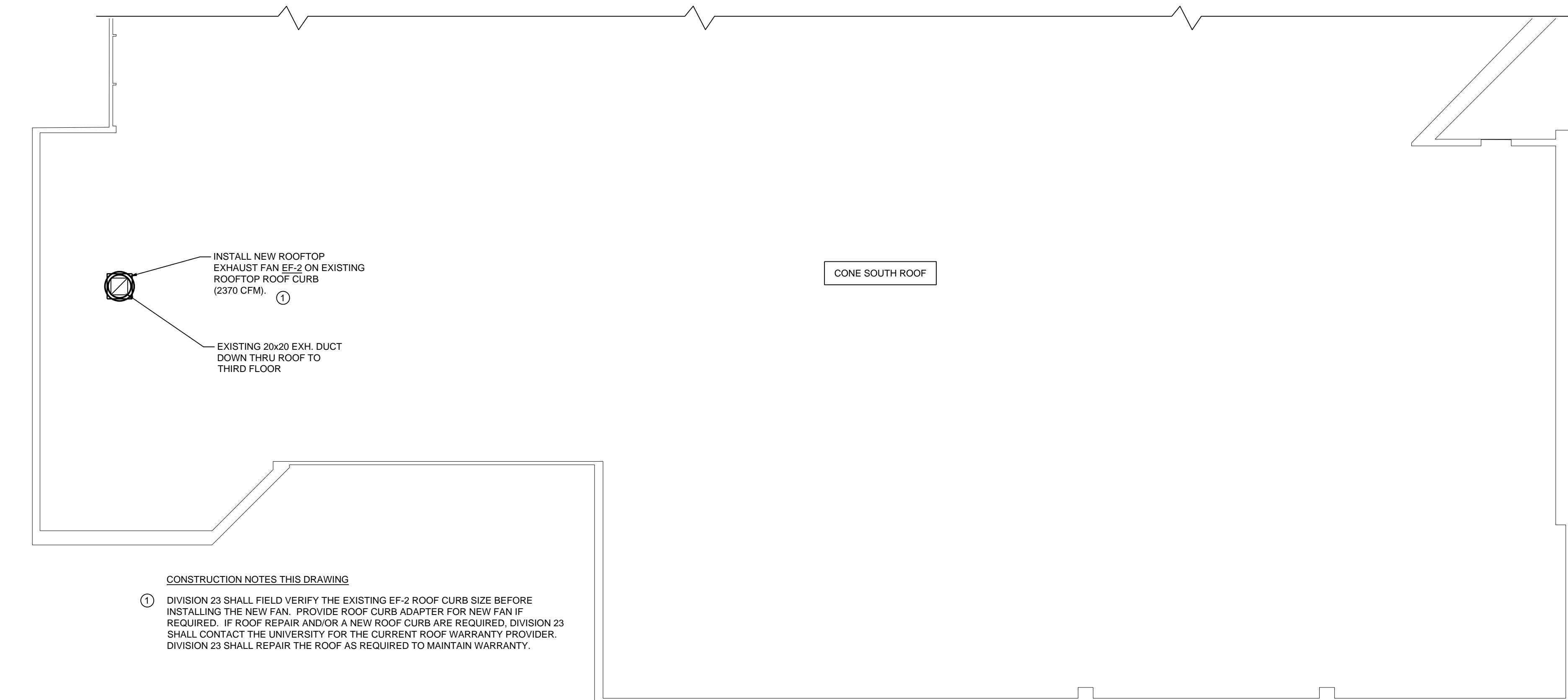

PARTIAL ROOF PLAN - MECHANICAL

SCALE: 1/8" = 1'-0"

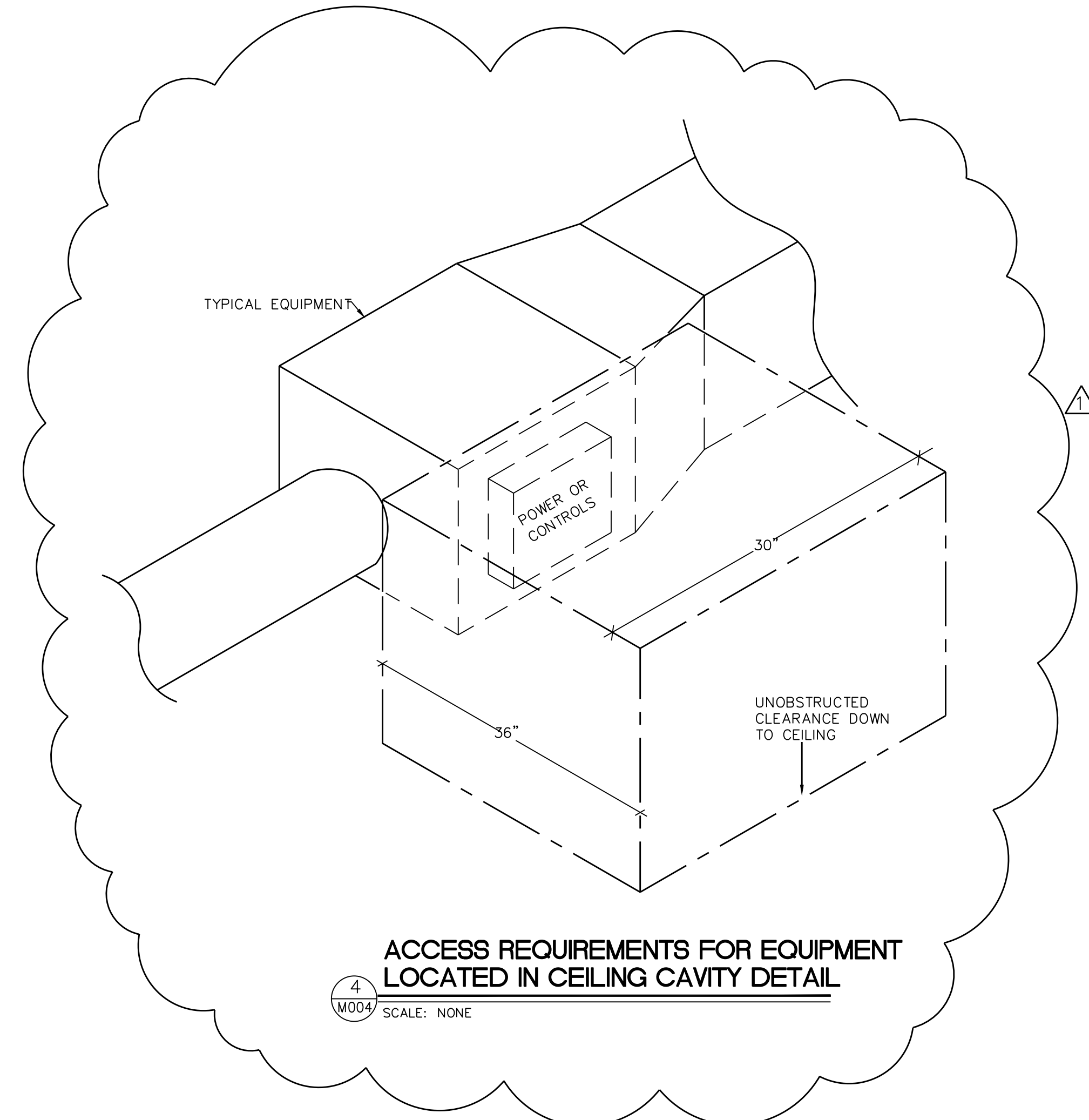
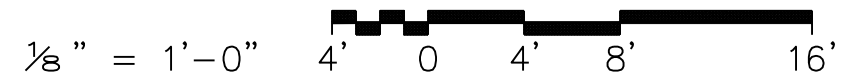

4 ACCESS REQUIREMENTS FOR EQUIPMENT LOCATED IN CEILING CAVITY DETAIL

SCALE: NONE

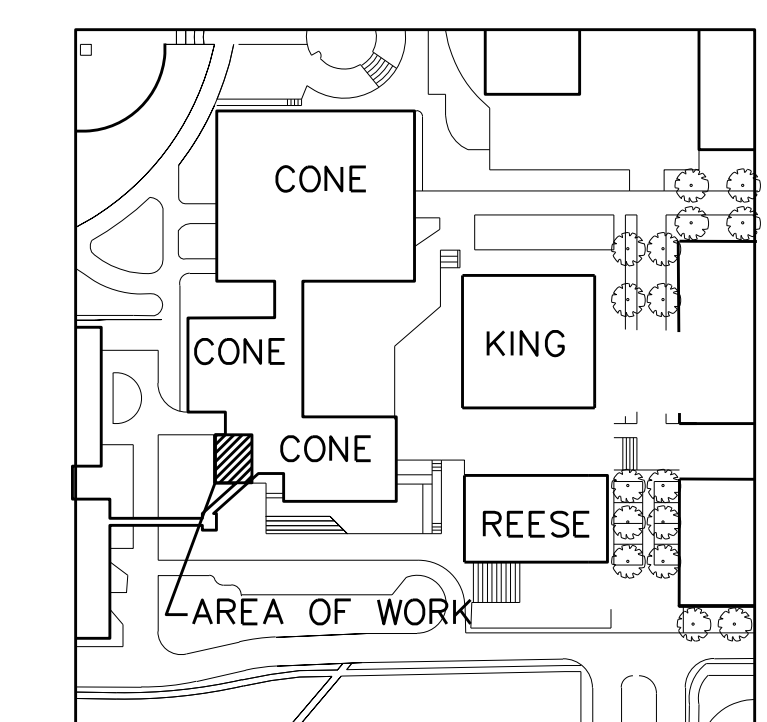

KEY PLAN

2151 Hawkins Street, Suite 500
Charlotte, North Carolina 28203
Post Office Box 32515
Charlotte, North Carolina 28232
Ph: 704/376-7072 | Fx: 704/376-4465
License no. C-0503



CONE CENTER HVAC MODERNIZATION

BID DOCUMENTS

SCO #16-12981-01

Charlotte, North Carolina

DRAWN BY: MDE
CHECKED BY: JLC
DATE: 07/18/2017
REVISIONS: 1

Digitally signed by James Currie
Date: 2017.07.17 15:23:04 -0400

216.084

COMMISSION NUMBER: 216.084

DRAWING TITLE:
MOTOR CONTROL SCHEDULE & HVAC ROOF PLAN

ADDENDUM 3 7/19/2017

DRAWING NUMBER:

M004