



Project Title
UNCC HVAC, Plumbing and Electrical Repairs - McEniry Electrical & Plumbing Package
 SCO ID # 20-22572-01A
 PM: JOHN BOAL

08/31/2021	-	100% CD REVIEW SET	DAB
09/28/2021	-	BID SET	DAB

Date:	Mark:	Description:	By:
-------	-------	--------------	-----

DEMO PLAN, FOUNDATION PLAN AND STRUCTURAL SECTION AND DETAILS

Proj. No.: 221.013	Scale: AS NOTED
Date: 08/31/2021	
Drawn By: TOM	Checked: LDW
Sheet No.:	

S100

ALL DIMENSIONS AND CONDITIONS MUST BE CHECKED AND VERIFIED ON SITE BY THE CONTRACTOR AND SUB-CONTRACTORS. THE PROJECT MANAGER SHALL BE NOTIFIED IN WRITING OF ANY DISCREPANCIES PRIOR TO PROCEEDING WITH THE WORK.
 © CMTA. - ALL RIGHTS RESERVED.

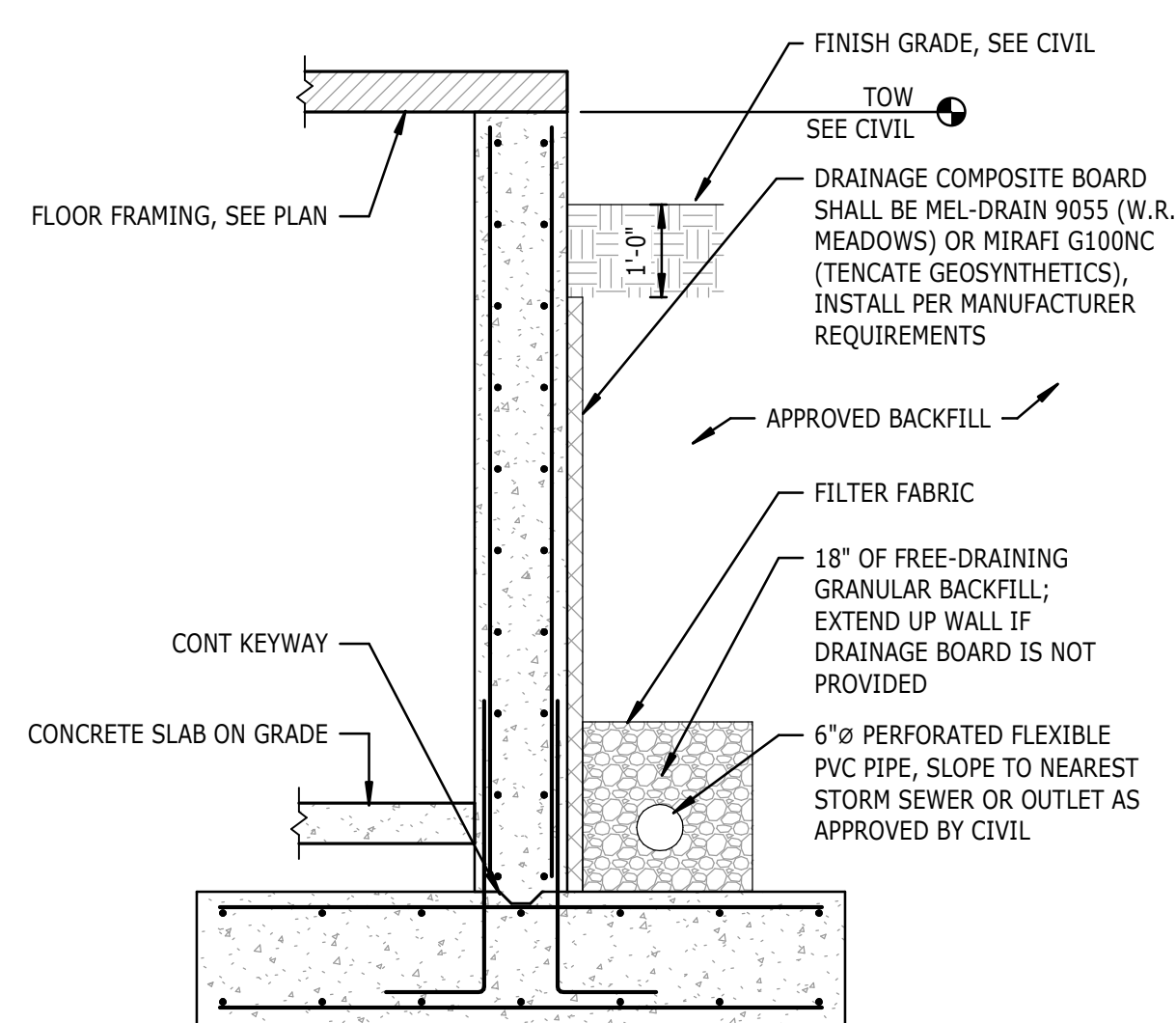

NOTES:
 1. THIS DETAIL IS INTENDED TO SPECIFY ONLY THE REQUIRED DRAINAGE SYSTEM FOR ALL BUILDING WALLS. SEE OTHER SECTIONS AND DETAILS FOR WALL AND FOOTING SIZES, REINFORCING, ETC.

7 TYPICAL WALL DRAINAGE SYSTEM
 S100 1/2" = 1'-0"

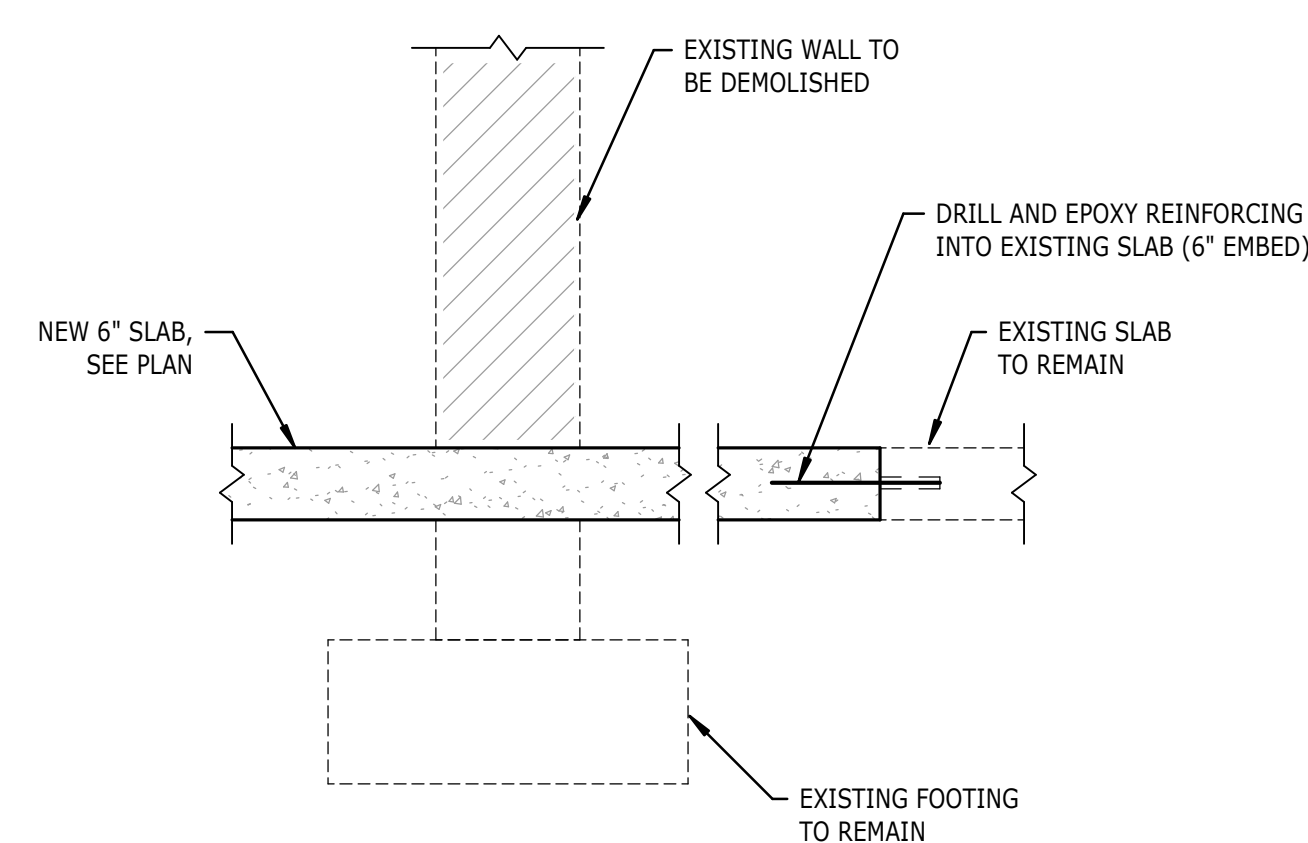

4 SECTION
 S100 3/4" = 1'-0"

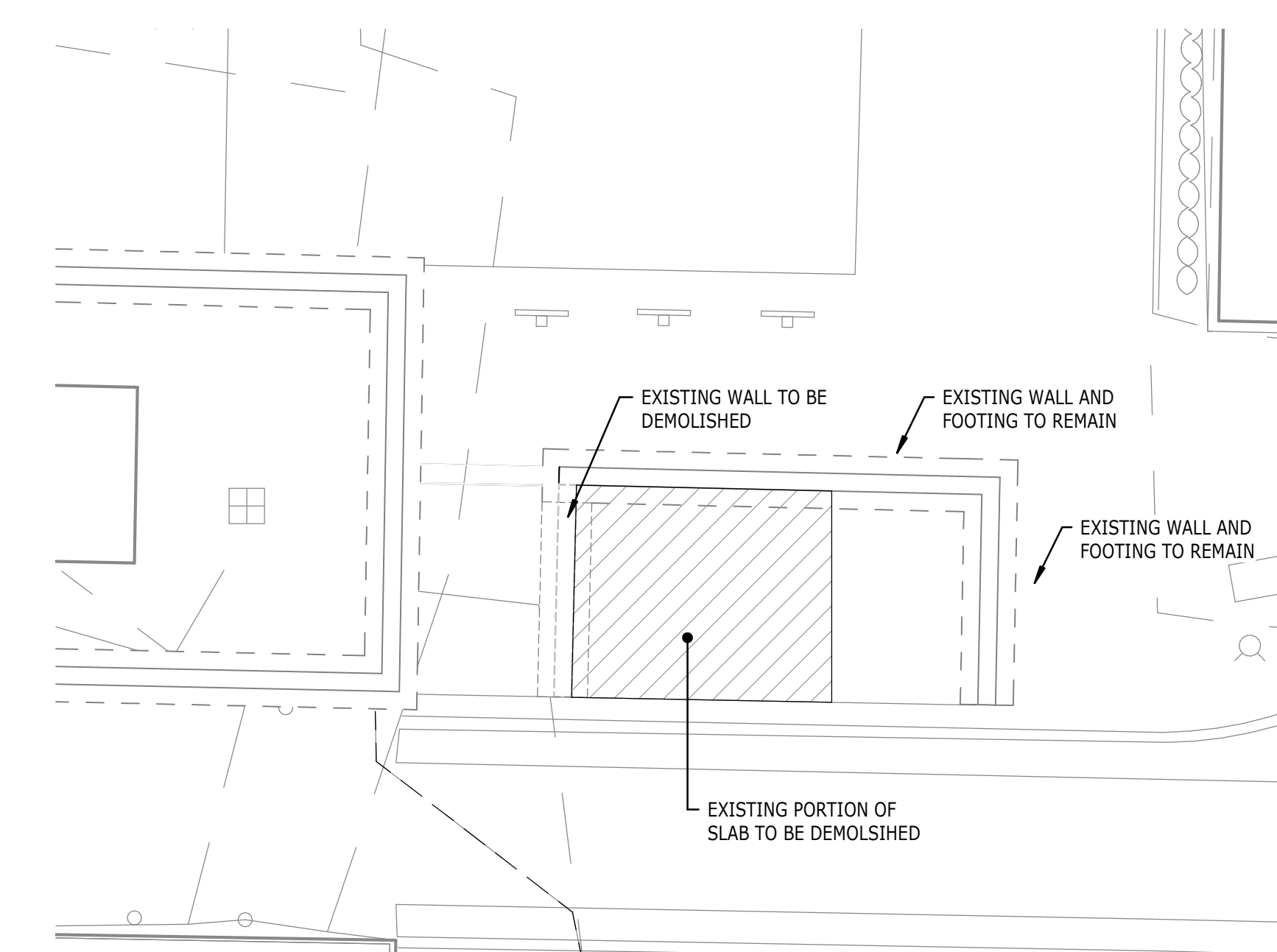

2 DEMO PLAN
 S100 1/8" = 1'-0"

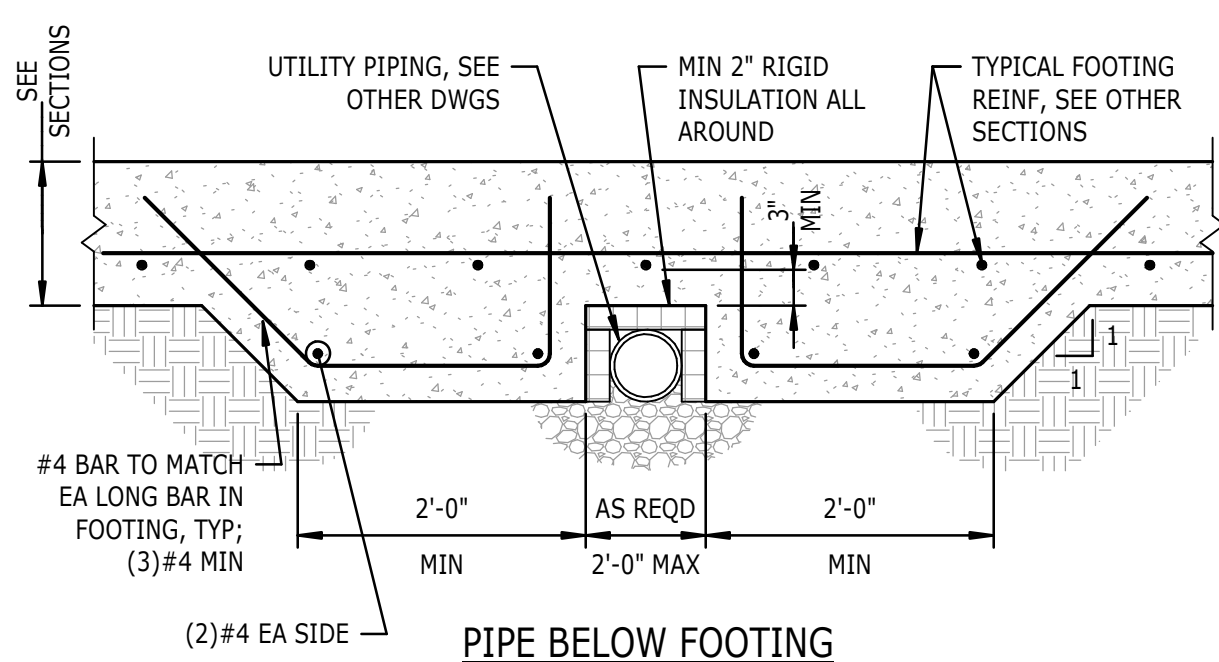

PIPE BELOW FOOTING

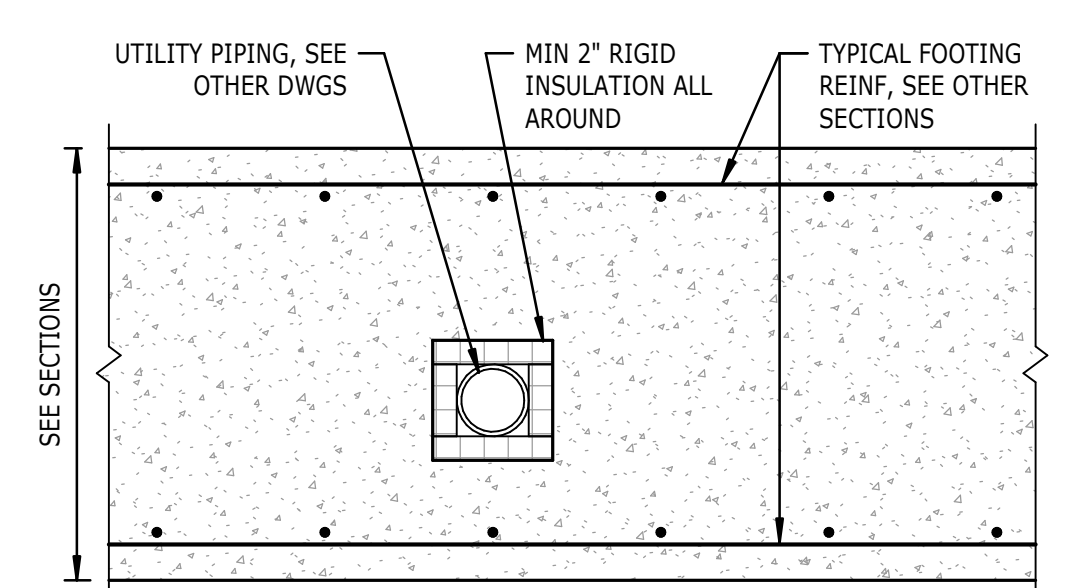

PIPE IN FOOTING

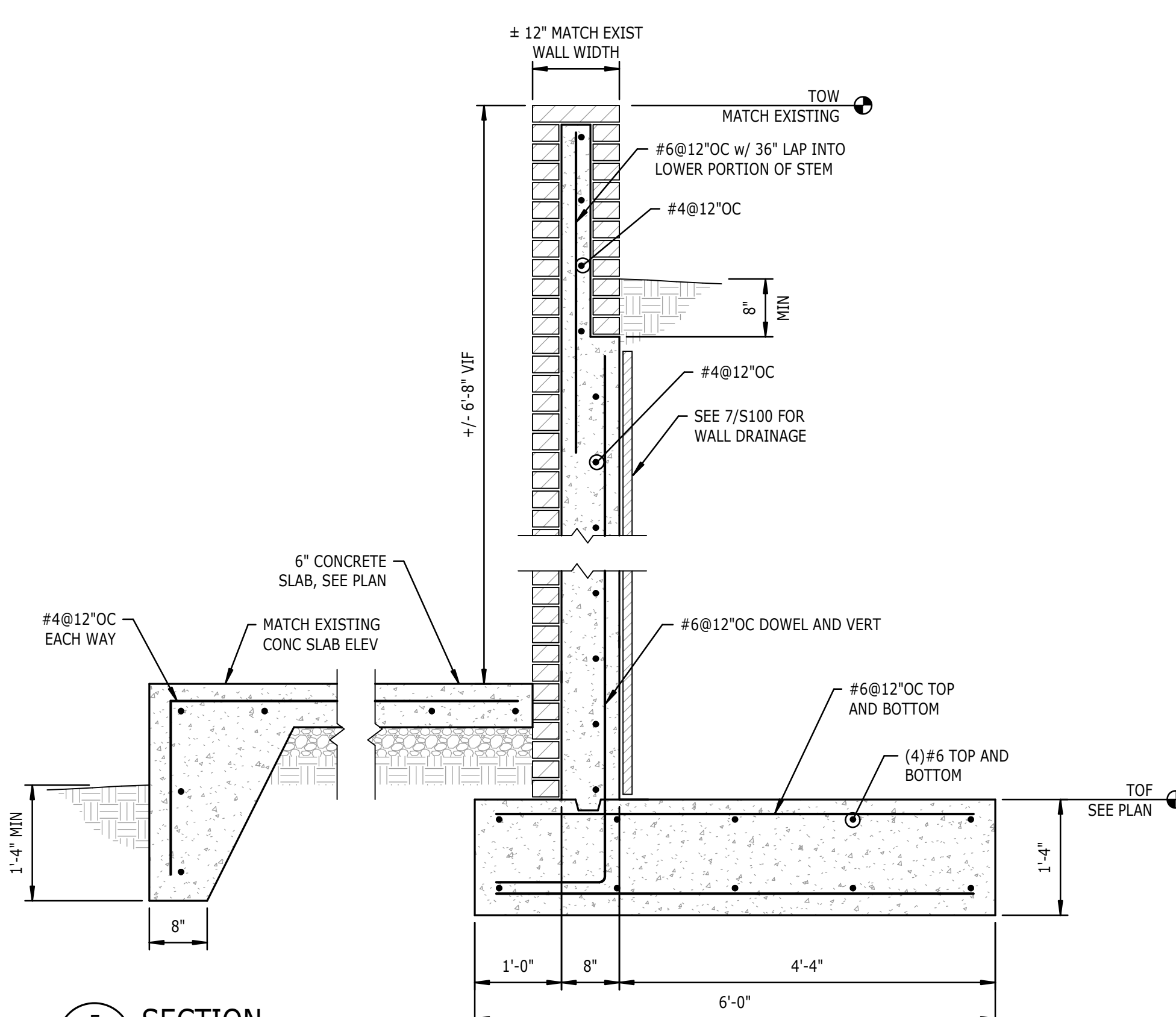

5 SECTION
 S100 3/4" = 1'-0"

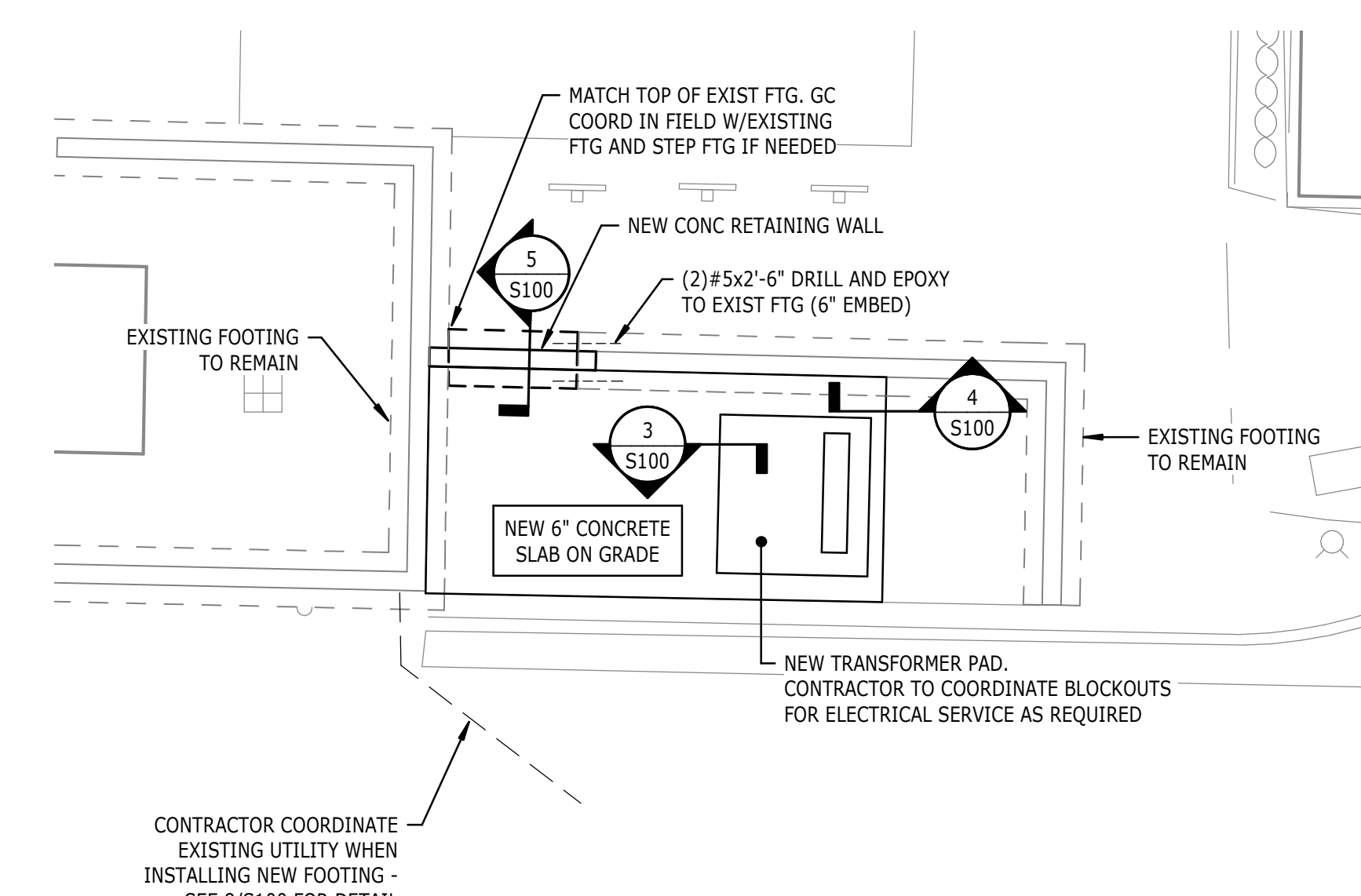

1 FOUNDATION PLAN
 S100 1/8" = 1'-0"

BAR SIZE	LEG DIM, "L"	EMBEDMENT, "D"		
		f _c = 3,000 PSI	f _c = 4,000 PSI	f _c = 5,000 PSI
#3	6"	6"	6"	6"
#4	8"	8"	7"	6"
#5	10"	10"	9"	8"
#6	12"	12"	10"	9"
#7	14"	14"	12"	11"
#8	16"	16"	14"	12"
#9	19"	18"	15"	14"
#10	22"	20"	17"	15"
#11	24"	22"	19"	17"

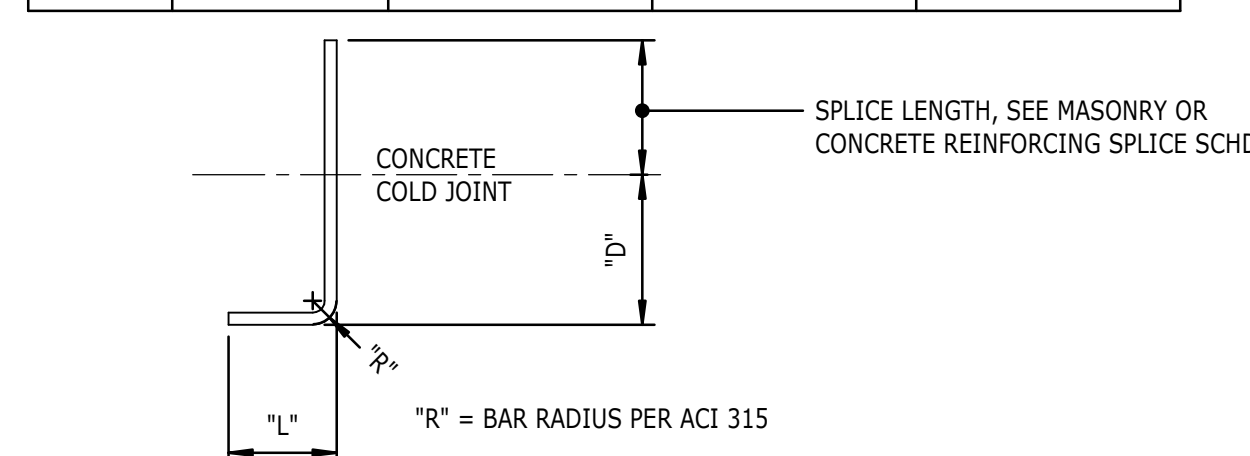

NOTES:
 1. FOR CONCRETE STRENGTHS NOT PROVIDED, USE THE EMBEDMENT LENGTH FOR THE LOWER CONCRETE STRENGTH AS SHOWN IN THE TABLE.
 2. DOWEL LENGTHS BASED ON NORMAL WEIGHT CONCRETE. FOR LIGHT WEIGHT, INCREASE DOWEL LENGTH "D" BY 30%.
 3. SIDE COVER ON BARS MUST BE GREATER THAN 2 1/2". END COVER ON 90° HOOKED BARS MUST BE GREATER THAN 2".
 4. FOR EPOXY-COATED BARS, INCREASE THE DOWEL LENGTH "D" BY 20%.

6 DOWEL EMBEDMENT LENGTH SCHEDULE
 S100 3/4" = 1'-0"

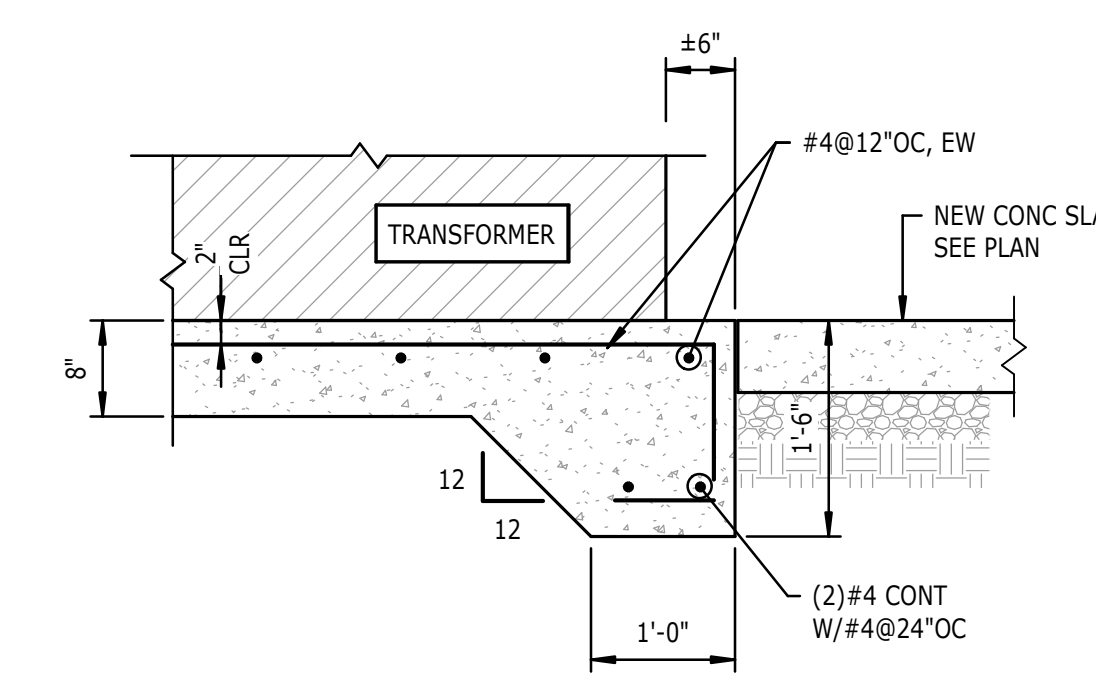

3 SECTION
 S100 3/4" = 1'-0"

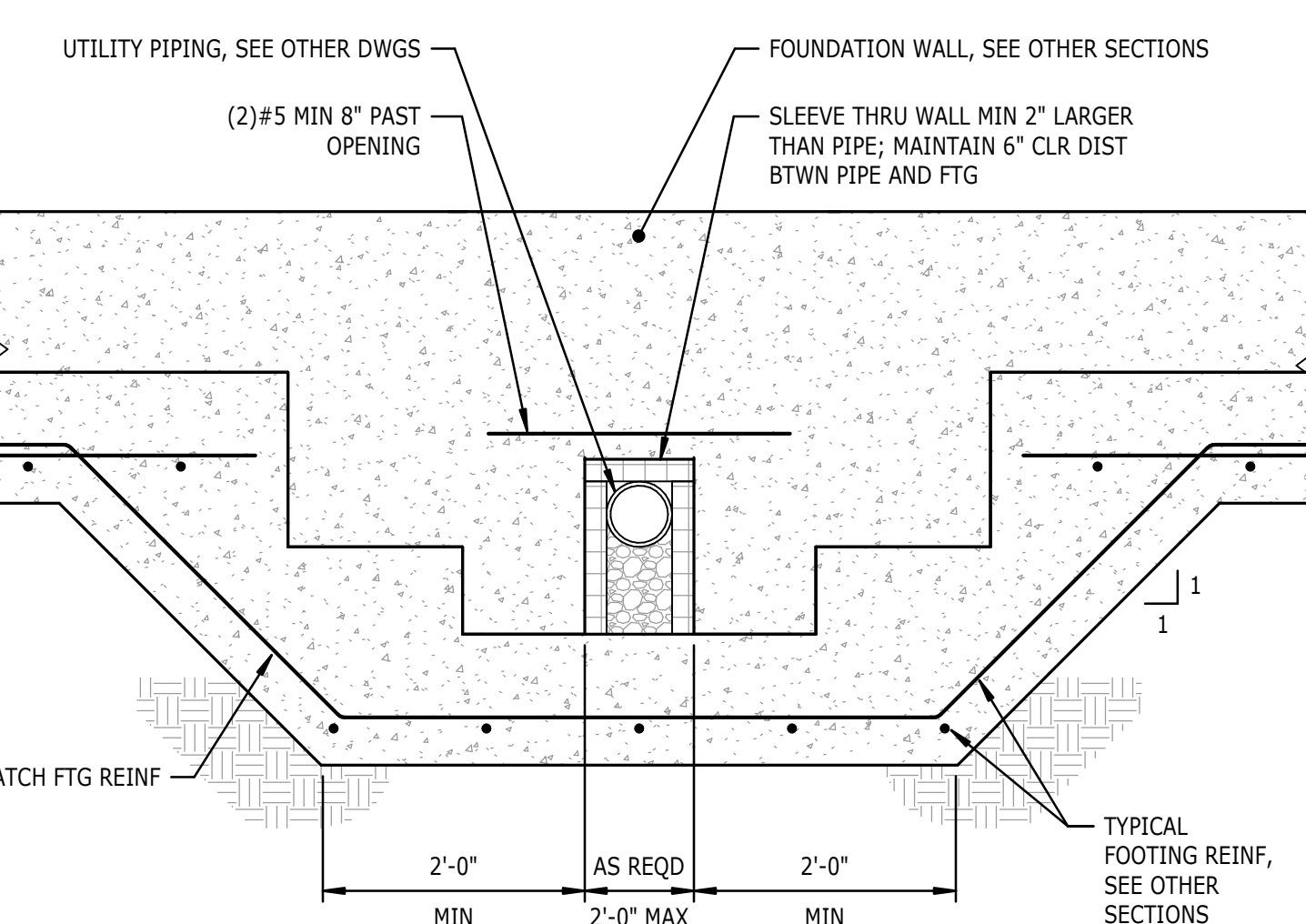

PIPE THRU WALL

8 TYPICAL UTILITY BELOW FOOTING
 S100 3/4" = 1'-0"



STEWART

101 N. TRYON ST., #1400 FIRM LICENSE # C-1051
 CHARLOTTE, NC 28202 www.stewartinc.com
 T 704.334.7925 PROJECT # C21057

FOR REFERENCE ONLY

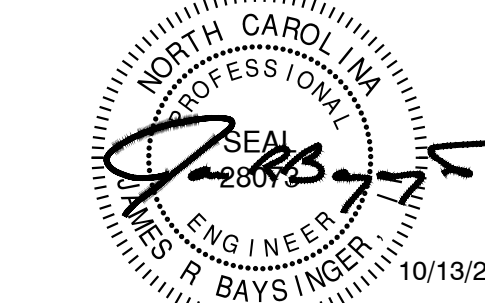

Project Title
UNCC HVAC, Plumbing and Electrical Repairs - McEniry Electrical & Plumbing Package
 SCO ID # 20-22572-01A
 PM: JOHN BOAL

08/04/2021	-	100% CD REVIEW SET	JRB
09/28/2021	-	BID SET	JRB

Date: _____ Mark: _____ Description: _____ By: _____

EXISTING CONDITIONS PLAN

Proj. No.: 221.013	Scale: AS NOTED
Date: 08/25/2021	Checked: JRB
Drawn By: MAD	Sheet No.:

C100

ALL DIMENSIONS AND CONDITIONS MUST BE CHECKED AND VERIFIED ON SITE BY THE CONTRACTOR AND SUB-CONTRACTORS. THE PROJECT MANAGER SHALL BE NOTIFIED IN WRITING OF ANY DISCREPANCIES PRIOR TO PROCEEDING WITH THE WORK.
 © CMTA. - ALL RIGHTS RESERVED.

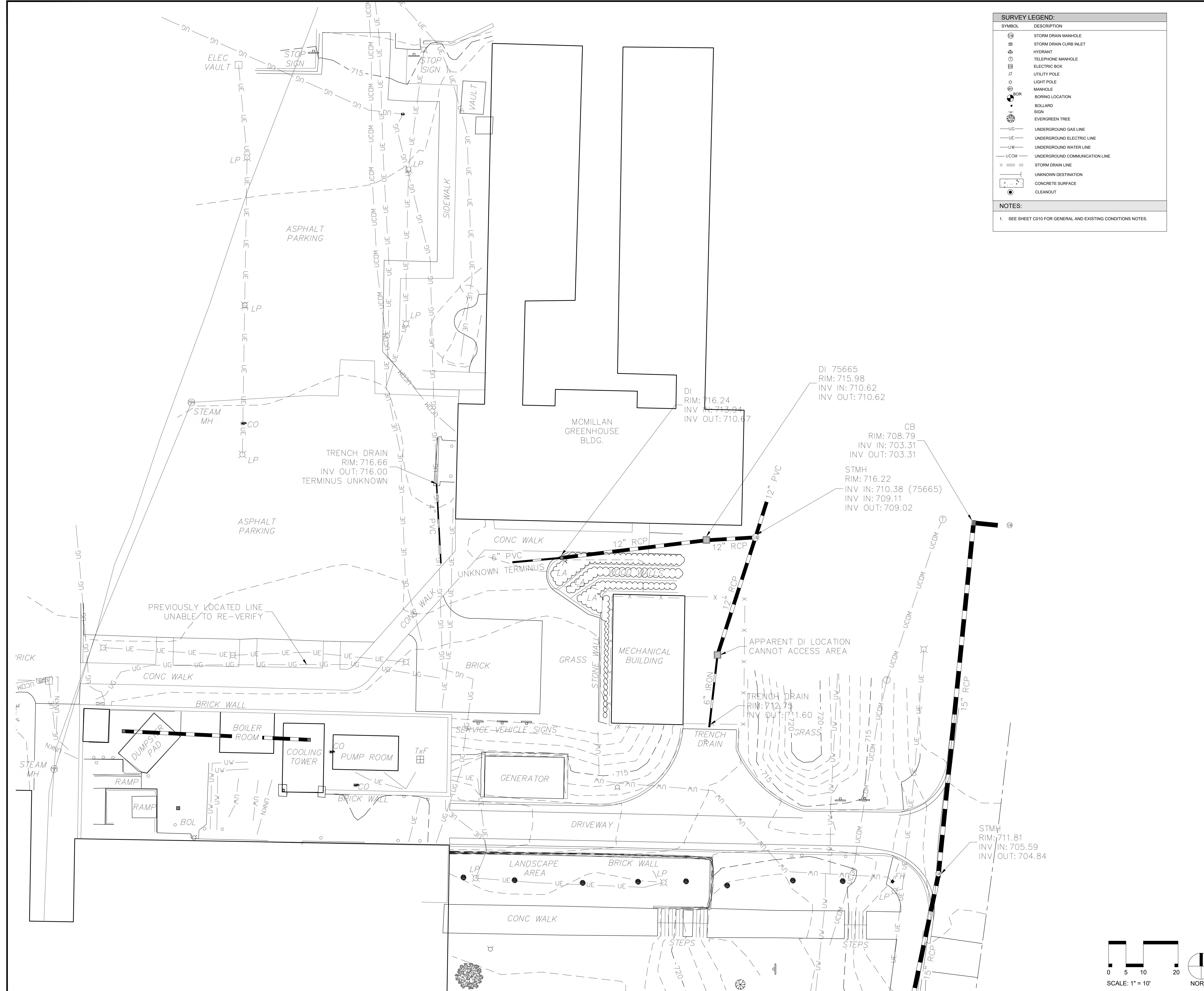

SURVEY LEGEND:

SYMBOL	DESCRIPTION
(Symbol)	STORM DRAIN MANHOLE
(Symbol)	STORM DRAIN CURB INLET
(Symbol)	HYDRANT
(Symbol)	TELEPHONE MANHOLE
(Symbol)	ELECTRIC BOX
(Symbol)	UTILITY POLE
(Symbol)	LIGHT POLE
(Symbol)	MANHOLE
(Symbol)	BORING LOCATION
(Symbol)	BOLLARD
(Symbol)	SIGN
(Symbol)	EVERGREEN TREE
(Symbol)	UNDERGROUND GAS LINE
(Symbol)	UNDERGROUND ELECTRIC LINE
(Symbol)	UNDERGROUND WATER LINE
(Symbol)	UNDERGROUND COMMUNICATION LINE
(Symbol)	STORM DRAIN LINE
(Symbol)	UNKNOWN DESTINATION
(Symbol)	CONCRETE SURFACE
(Symbol)	CLEANOUT

NOTES:

- SEE SHEET C010 FOR GENERAL AND EXISTING CONDITIONS NOTES.

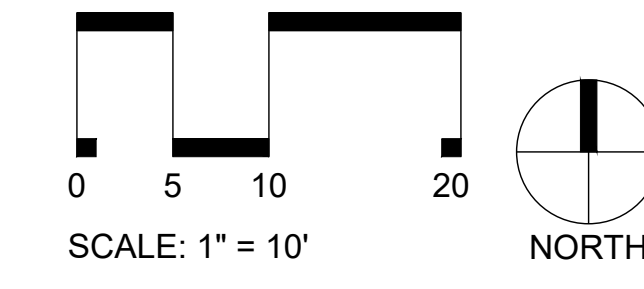

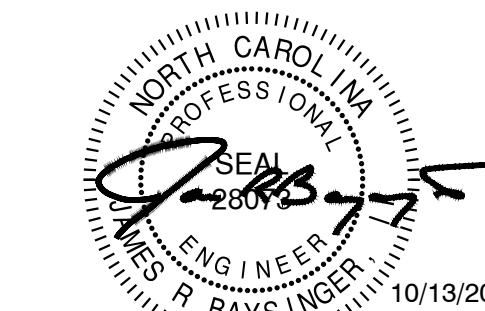

Project Title
UNCC HVAC, Plumbing and Electrical Repairs - McEniry Electrical & Plumbing Package
 SCO ID # 20-22572-01A
 PM: JOHN BOAL

08/04/2021	-	100% CD REVIEW SET	JRB
09/28/2021	-	BID SET	JRB
10/13/2021	1	ADDENDUM #2	JRB

Date: _____ Mark: _____ Description: _____ By: _____

SITE PLAN

Sheet Title:
 Proj. No.: 221.013 Scale: AS NOTED
 Date: 08/25/2021
 Drawn By: MAD Checked: JRB

C300

ALL DIMENSIONS AND CONDITIONS MUST BE CHECKED AND VERIFIED ON SITE BY THE CONTRACTOR AND SUB-CONTRACTORS. THE PROJECT MANAGER SHALL BE NOTIFIED IN WRITING OF ANY DISCREPANCIES PRIOR TO PROCEEDING WITH THE WORK.
 © CMTA. - ALL RIGHTS RESERVED.

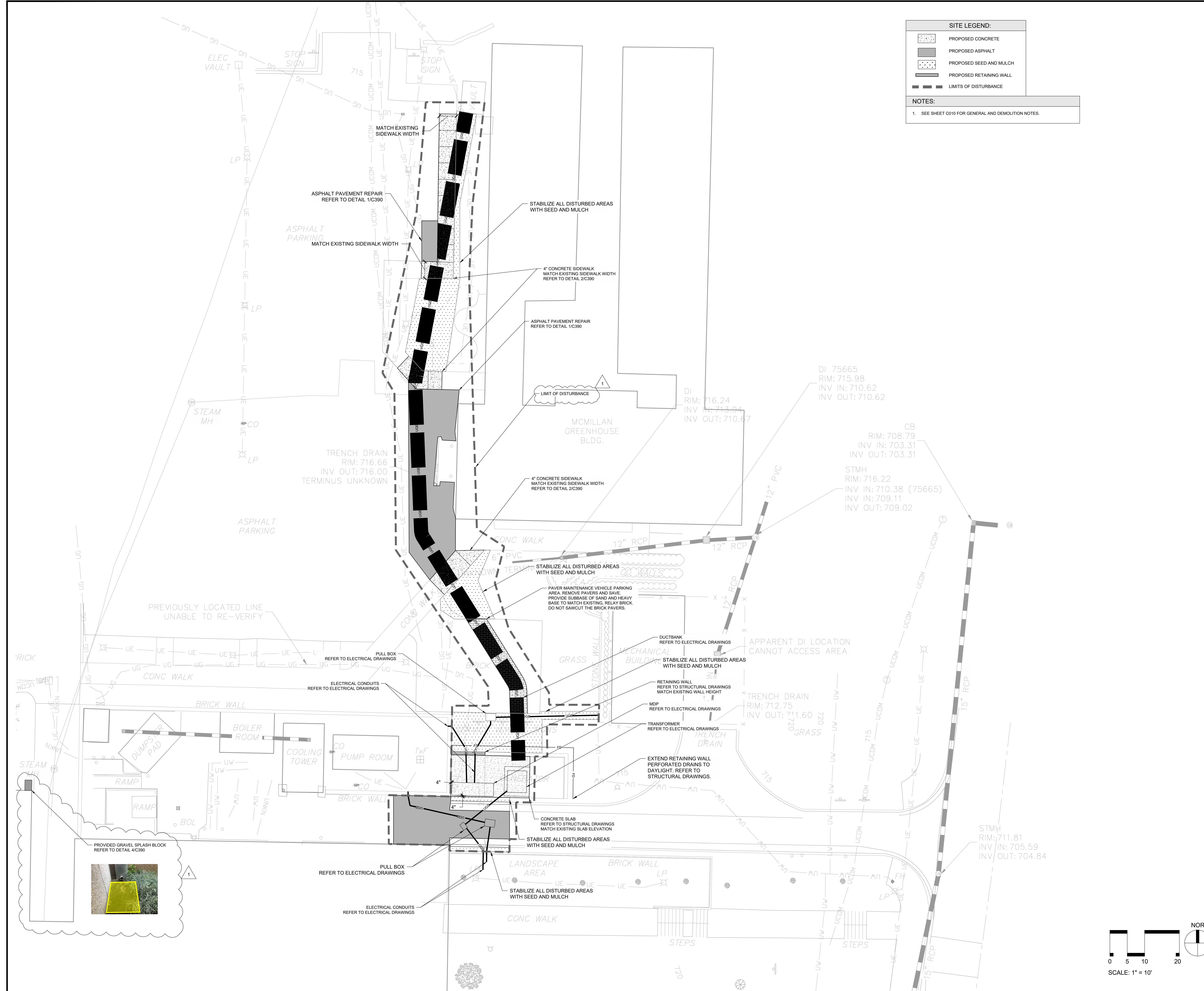

SITE LEGEND:

- PROPOSED CONCRETE
- PROPOSED ASPHALT
- PROPOSED SEED AND MULCH
- PROPOSED RETAINING WALL
- LIMITS OF DISTURBANCE

NOTES:

- SEE SHEET C010 FOR GENERAL AND DEMOLITION NOTES.

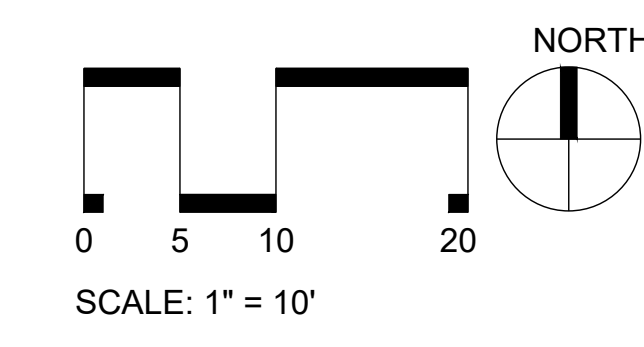

2021 HUB Contractors List (Master)

Minority Categories						
Black/African American (B), Hispanic (H), Asian American (A), American Indian (AI or I), Female (F), Socially & Economically Disadvantaged (D) NC Small Business Enterprise (S) NC Small Business Enterprise (NC SBE) certified - 8/27/21						
CATEGORY	CONTRACTOR	HUB/NC SBE	CONTACT	TELEPHONE	EMAIL	EMAIL
Acoustical Tile						
	NC Interiors Contracting	H	Nancy Palacios	(704) 529-0140	nancy@ncinteriorcontracting.com	
	Mekki Modular Systems	B	Gamal Mekki	(704) 676-0050	mekmodsys@gmail.com	
	Charlotte Ceiling Company	F	Constance Stidd	(704) 888-5088	charceil@aol.com	
	Sears Contracting	F	Lynn Sears	(919) 754-0750	lsears@searscontract.com	
	Nichols Custom Builders & Design	B	Kwesi Nichols	(704) 400-6786	support@nicholscustombuildersanddesign.com	
	Munoz Contracting	H	Jose Munoz	(704) 713-6308	munozcontracting@aol.com	
	NJR Construction LLC	B	Edward Roper	(704) 258-1531	edroper.njrconstruction@gmail.com	
	Diamond Touch Construction	B	Andrea Pettitt	(919) 787-3838	officemanager@diamondtouch.net	aly@diamondtouch.net
	United Painting Services	H	Leonardo Andrade	(704) 962-0563	leo@unitedpaintingservices.com	
Asbestos Abatement						
	Abatemaster, Inc	F	Angela Tesh	(336) 731-4396	angela_abatemaster@yahoo.com	
	Vistabution, LLC	B	Clarence Mann	(919) 844-9375	cmann45@bellsouth.net	
	Janezic Building Group	F	Lori Janezic	(919) 870-2988	ljanezic@raleigh.twcbc.com	
	Double D Construction Services, Inc.	F/YES	Tracy Doub	(336) 922-4126	ddtrucking@triad.twcbc.com	sstanley@triad.twcbc.com
	Elevated Environmental Corporation	F/YES	Stephanie Gower	(800) 718-7144	info@elevatedenvironmental.com	
Asphalt Paving/Grading						
	James Seals & Stripes	F/YES	Jeannie Reid	(704) 202-0404	jeannie@jss-inc.com	
	Oliver Paving	F	Ruth Oliver	(704) 392-2462	oliver@oliverpaving.com	
	Siteworks, LLC	F	Mellissa Bovit	(704) 588-3055	mbovit@siteworks-llc.com	
	USA Concrete and Contractual Services	B	Jerry Dunlap	(980) 622-7833	jerry@dunlapconcrete.com	
	Ultimate Asphalt and Concrete	B	Everett smith	(704) 905-3767	ultimateasphaltandconcrete@gmail.com	
	L. T. Hedrick Construction Co, Inc dba Hedrick Grading and Paving	F	Tammy Hedrick	(336) 746-5115	tamtarheel@hotmail.com	
	Luvall Asphalt Services	B	Donald Britten	(980) 256-2807	luvallasphaltservices@gmail.com	paving@luvallasphaltservices.com
	ASJ Wilson Constructuon	B	Josephus Wilson	(336) 272-7722	estimator@asiwilsonconstruction.com	

2021 HUB Contractors List (Master)

Builder's Supplies						
	Ram Tool and Supply	F	Hillery Head	(205) 714-3300	wbe@ram-tool.com	
Cleaning - Construction & Final Cleaning						
	Mr Clean Maintenance Company	B	Michael Murray	(704) 200-0047	michaelmurray@mrleanservices.com	
	Clean Bean	B	Clarence Bynum	(704) 605-4780	cleanbeanllc@yahoo.com	
	Pro Klean	F/YES	Debbie McMillan	(704) 504-9588	debbie@prokleaninc.com	
	Access Services	B/YES	Kevin Smith	(704) 644-5529	kevin@access-services.biz	frank@access-services.biz
	Miriam Davis Cleaning, LLC	B	Miriam Davis	(704) 201-6111	miriam@miriamdaviscleaning.com	
	Hopkins Services, Inc.	B	Anthony Hopkins	(336) 547-0401	hopkinsservices@bellsouth.net	
	GrimeGuru Janitorial Service	B	Brigitte Hampton	(336) 710-4406	brigitte@grimeguru.com	
	Golden Cleaning Service	B	Charles Osborne	(704) 650-2900	goldencleaningcharlotte@gmail.com	
	United Painting Services	H	Leonardo Andrade	(704) 962-0563	leo@unitedpaintingservices.com	
	Karma Contracting	B/YES	Karim Razzak	(336) 757-6984	karmacontractinginc@gmail.com	
	Boller Logistics, LLC	B/YES	Kaylen Boller	(704) 905-9817	kbollerlogistics@gmail.com	bollertransport@gmail.com
	All Things Professional Cleaning	B	Erica Everett	(704) 345-3976	erica@allthingscleaning.com	
Concrete						
	Johnson Concrete Company	F	Gregg Swartz	(704) 363-9839	gswartz@johnsoncmu.com	
	P & D Architectural Precast	F	Gladys Adkins	(252) 566-9811	pdarchprecast@gmail.com	
	Martinez Company	H	Luis Martinez	(919) 402-6846	luis342@bellsouth.net	
	Camps Construction	H	Kevin McCutchen	(704) 321-1492	kmccutchen@campconstruction.com	
	SVG Concrete Services	H	Gary Anderson	(919) 567-0044	ganderson@svgconcrete.com	svg@svgconcrete.com
	ASJ Wilson Constructuon	B	Josephus Wilson	(336) 272-7722	estimator@asiwilsonconstruction.com	
	Harris Concrete and Construction, Inc.	B/YES	Sean Harris	(336) 362-3178	harrisconcrete@triad.rr.com	
	Lacayo Concrete Flatwork, Inc.	H	Ernest Lacayo	(336) 364-2252	ernestlacayo@yahoo.com	
	PCM Construction, Inc.	H	Juan Pena	(336) 527-4536	jspeana@pcmconstructioninc.net	
	Concrete Solutions by JH&S LLC	B/YES	James Hickman	(336) 782-1968	estimating@concretesolutionsihs.com	
	Locke-Lane Construction Inc	D	Andrew Sherrill	(704) 585-6625	dsherrill@lockelaneconstruction.com	
	Ram Tool and Supply	F	Hillery Head	(205) 714-3300	wbe@ram-tool.com	
	Luvall Asphalt Services Incorporated	B	Donald Britten	(980) 256-2807	luvallasphaltservices@gmail.com	Curb & Gutter
Demolition						
	Vistabution, LLC	B	Clarence Mann	(877) 288-9656	cmann45@bellsouth.net	
	Abatemaster, Inc	F	Angela Tesh	(336) 731-4396	angela_abatemaster@yahoo.com	
	Access Services	B/YES	Kevin Smith	(704) 644-5529	kevin@access-services.biz	frank@access-services.biz
	All-Pro Builders & Restoration	B	Gerald Carr	(704) 915-9674	allprobuilders1@yahoo.com	

2021 HUB Contractors List (Master)

	Clement Construction Corporation	B/YES	Phillip Clement Sr.	(336) 661-2488	clementconst@yahoo.com	
	Double D Construction Services, Inc.	F/YES	Tracy Doub	(336) 922-4126	ddtrucking@triad.twcbc.com	sstanley@triad.twcbc.com
	Elevated Environmental Corporation	F/YES	Stephanie Gower	(800) 718-7144	info@elevatedenvironmental.com	
Doors/Frames & Hardware						
	Southern Door Supply	F/YES	Kathleen Fennell	(704) 332-4460	kfennell@southerndoorsupply.com	
	SAF Technologies	F	Alison Weeks	(704) 844-0955	alison.parrish@saftechnologies.com	alan.weeks@saftechnologies.com
	Stuart Page	F	Kimberly Page	(704) 545-0695	kim@stuartpagecompany.com	stuart@stuartpagecompany.com
	DWS Steel Structures, Inc.	F	Marie Anderson	(336) 996-0500	marie@dws-structures.com	
	FM Supplies	B	fassil Mitiku	(336) 391-8653	fmitiku@triad.rr.com	
	GP Supply Company	B	Antonio Wallace	(336) 274-7615	awallace@gpsupplycompany.com	david@gpsupplycompany.com
Drywall & Metal Framing						
	Northedge, LLC (Chavez Interiors LLC)	H	Jose Chavez	(336) 969-2669	joseg@chavezinteriors.com	
	Nichols Custom Builders & Design	B	Kwesi Nichols	(704) 400-6786	support@nicholscustombuildersanddesign.com	
	Sears Contract	F	Lynn Sears	(919) 754-0750	lsears@searscontract.com	
	Latino Group Drywall	H	Alejandro Anaya	(828) 465-3147	jg_drywall@att.net	
	Munoz Contracting	H	Jose Munoz	(704) 713-6308	munozcontracting@aol.com	
	NC Interiors Contracting	H	Nancy Palacios	(704) 529-0140	nancy@ncinteriorcontracting.com	
	Taylor Interiors	B/YES	Tarris Arnold	(704) 886-4813	taylorinteriorsllc@yahoo.com	
	Melco & Associates	H	Melissa Alejandro	(704) 348-4588	melissa@melcofirestopping.com	
	Piedmont Stucco	H	Faye Fenske	(704) 504-1313	piedmontstucco.estimated@gmail.com	
	The AZ Group Contractors	H	Asael Ramos	(980) 207-4561	theazgroup3@aol.com	
	Armen Construction	H/YES	Victor Ariza	(704) 953-7459	armencontractors@aol.com	
	NJR Construction LLC	B	Edward Roper	(704) 258-1531	edroper.njrconstruction@gmail.com	
	United Painting Services	H	Leonardo Andrade	(704) 962-0563	leo@unitedpaintingservices.com	
	Karma Contracting	B/YES	Karim Razzak	(336) 757-6984	karmacontractinginc@gmail.com	
Dumpster Services/Waste Removal						
	No Firms Identified At This Time					
Electrical						
	SAF Technologies	F	Alison Weeks	(704) 844-0955	alison.parrish@saftechnologies.com	
	Caryl Mechanicals dba The Boswell Group	F/YES	Libby Caryl	(704) 289-8986	lcaryl@theboswellgroup.com	
	Bernard Irby Inc.	B	Julian Irby	(704) 810-1801	contact@bernardirby.com	calvin@bernardirby.com
	Republic Electric Company	H	Rodney Scott	(704) 643-0180	rodneys@republicelect.com	

2021 HUB Contractors List (Master)

	Caryl Mechanicals dba The Boswell Group	Y/YES	Libby Caryl	(704) 289-8986	lcaryl@theboswellgroup.com	
Firestopping						
	Firestop Carolinas	F	Pamela Wellons	(704) 662-7720	pamw@firestopcarolinas.com	robin@firestopcarolinas.com
	RS Blythe	F	Jan Blythe	(704) 391-0667	jan@blytheandassoc.com	
Flooring						
	Anointed Flooring	B	Camisha Farris	(704) 510-8906	cfarris@anointedflooring.com	
	Garmon & Company	F	Bettye Garmon	(704) 331-0886	bettye@garmonandcompany.com	
	Black Contracting	F/YES	Lois Black	(704) 694-3200	blackcontracting@hotmail.com	
	Lomax Tile & Stone Supply	F	Laura Hannah	(828) 669-2988	lhannah@lomaxtile.com	
	The AZ Group Contractors	H	Asael Ramos	(980) 207-4561	theazgroup3@aol.com	
	Carolina Custom Installation	F	Sally Nichols	(704) 568-7277	sally@cci-floors.com	
	Mekki Modular Systems	B	Gamal Mekki	(704) 676-0050	mekmodsys@gmail.com	
	Carolina Sports Floors, LLC	F	LuAnne Serpas	(336) 317-8218	sales@carolinasportsfloors.com	
	Santis Flooring Services	H	Rodolfo Santis	(336) 674-5972	santisflooringserviceinc@gmail.com	
	Funderburk Unlimited Services, Inc.	B	Kenneth Funderburk	(704) 363-0383	funderburkunlimitedsrv@gmail.com	
	Vision Flooring	F	Vickie Kindred	(704) 921-2591	vkindred@visionflooring.com	
	University Flooring Solutions	B	William Smallwood	(980) 939-3860	smallwcarp@gmail.com	
	Diamond Touch Construction	B	Andrea Pettitt	(919) 787-3838	officemanager@diamonddtouch.net	aly@diamonddtouch.net
	Regional Construction Corp	B	Orlando McClean	(704) 426-3701	orlandoamcclean@gmail.com	
	United Painting Services	H	Leonardo Andrade	(704) 962-0563	leo@unitedpaintingservices.com	
	Karma Contracting	B/YES	Karim Razzak	(336) 757-6984	karmacontractinginc@gmail.com	
General Trades						
	Access Services	B/YES	Kevin Smith	(704) 644-5529	kevin@access-services.biz	frank@access-services.biz
	BSL Galbreath	B	Artis Galbreath	(980) 722-0878	g_artis@bellsouth.net	
	ML Builders	B/YES	Shawn McCullough	(864) 275-2664	shawn@mlbuilderssc.com	
	NC Interiors Contracting	H	Nancy Palacios	(704) 529-0140	nancy@ncinteriorcontracting.com	
	Diamond Touch Construction	B	Andrea Pettitt	(919) 787-3838	officemanager@diamonddtouch.net	aly@diamonddtouch.net
	Nia Construction	B	Harold Seymour	(704) 957-4722	harry.seymour@niaconstruction.com	
	Queen Boss Properties, LLC	B/YES	Robert Grooms	(704) 778-1008	queenbossproperties@gmail.com	
	Sterling Construction Services	B/YES	Lee Addo	(336) 978-2631	laddo@sterlingconstructionservices.net	
	Regional Construction Corp	B	Orlando McClean	(704) 426-3701	orlandoamcclean@gmail.com	
	RS Blythe	F	Jan Blythe	(704) 391-0667	jan@blytheandassoc.com	
	Armen Construction	H/YES	Victor Ariza	(704) 953-7459	armencontractors@aol.com	
	Reliable Solutions Construction	H	Johanna Suarez	(704) 449-3542	johanna@reliablerestorations.net	

2021 HUB Contractors List (Master)

HVAC/Mechanical						
	Superior Mechanical Systems	B	Leonard Burch	(704) 335-1942	prossell@superiormsinc.com	lburch@superiormsinc.com
	Quate Industrial	F	Rusty Quate	(919) 596-5963	rquate@quateindustrial.com	shiggins@quateindustrial.com
	Wallace Mechanical Supply	B	Wallace Funderburk	(843) 537-4277	inc_wallace@bellsouth.net	
	A1 Quality	AI	Christy Senior	(704) 331-9294	seniorc@bellsouth.net	
	Unitary Systems	F/YES	Elaine Avery	(919) 400-5902	eavery@unitarysystems.com	
	TEW Equipment Solutions	F	Lynn Tew	(704) 573-5476	ltew@tewequipment.com	
	FM Supplies	B	Fassil Mitiku	(336) 391-8653	fmitiku@triad.rr.com	
	GP Supply Company	B	Antonio Wallace	(336) 274-7615	awallace@gpsupplycompany.com	david@gpsupplycompany.com
	Guilford Plumbing Supply	F/YES	Brad Yates	(336) 274-3761	byates@guilfordplumbingsupply.com	smccraw@guilfordplumbingsupply.com
	E. Luke Greene Company	F	Jeff Jones	(865) 933-4807	jeffjones@elukegreene.com	josephine@elukegreene.com
						steve@elukegreene.com
	Eastern Power Technologies	F	Shelby Jones	(704) 200-3645	shelby.jones@easternfirst.com	
	The Barr Group of Nashville, Inc.	F	James Murray	(615) 574-7176	james@barrgroupinc.com	
	Chavis' Inc	AI	Fitzgerald Chavis	(910) 844-2000	fitz.chavis@chavisinc.com	
	Catawba Mechanical Services, LLC	F/YES	Kathryn Early	(704) 399-8786	tinaearly@catawbamechanical.com	
Insulation						
	A1 Quality, Inc	I	Christy Senior	(704) 331-9294	seniorc@bellsouth.net	
	E. Luke Greene Company	F	Jeff Jones	(865) 933-4807	jeffjones@elukegreene.com	josephine@elukegreene.com
						steve@elukegreene.com
	Melco & Associates, Inc	HA	Melissa Alejandrop	(704) 348-4588	melissa@melcofirestopping.com	
	FJP Insulators, Inc	F	Maria Pellegrino	(919) 772-5012	fjpinsulators@raleigh.twcbc.com	
	Reliable Insulation Enterprise	F	Vernie Pettit	(704) 732-8444	vernie@reliableinsulation.net	
	G&T Insulation Services	H	Javier Gonzalez	(336) 345-6480	gandtinsulationservices@gmail.com	
	R&F Insulation Group	H	Brian Ramirez	(704) 298-5514	bramirez229@gmail.com	erami4845@gmail.com
Landscaping/Erosion Control						
	Sides Contracting Company	F	Susan Sides	(336) 249-8300	regina@sidesseeding.com	
	Dunlap Lawn Service	F	Karen Mills	(336) 282-3636	dlsinc@dunlaplawnservice.com	
	Mid Atlantic Erosion Control, Inc.	AA	Catherine Fowler	(704) 483-1100	maerosion@yahoo.com	
	Union Grove Landscape	F	Kim Baucom	(704) 233-0253	baucom1@aol.com	
	Canady's Landscape & Erosion Control	F/YES	Stefanie Canady	(336) 236-1182	canadyserosion@gmail.com	canadyslandscaping@gmail.com
	Carolina Environmental Contracting, Inc.	F	Joanne Cheatham	(336) 320-3849	ceci@carolinaenvironmentalcontracting.com	
	Grants Creek Nursery	F/YES	Meredith Croom	(910) 353-0326	grantscreeknursery@yahoo.com	

2021 HUB Contractors List (Master)

Masonry						
	G&Y Masonry	B	George West	704-906-2243	george.west@gymasonryinc.com	
	Gray Circle Material Sales	F	Julie Griffin	(704) 351-0183	jgriffin@griffinmasonry.com	
	Johnson Concrete Company	F	Gregg Swartz	(704) 363-9839	gswartz@johnsoncmu.com	
	P & D Architectural Precast	F	Gladys adkins	(252) 566-9811	pdarchprecast@gmail.com	
	Armen Construction	H/YES	Victor Ariza	(704) 953-7459	armencontractors@aol.com	
	The Masonry Company, Inc.	H	Jennifer Martinez	(336) 492-2685	jennmtz@aol.com	
	Honeycutt Masonry, Inc.	F/YES	Misty Honeycutt	(704) 902-0325	mhoneycutt@yadtel.net	
	Johnson & Johnson Masonry	B/YES	Cathey Johnson	(336) 288-8813	nj423@bellsouth.net	
Millwork/Casework						
	KID Construction Company	B/YES	Kevin Burns	(704) 277-4679	ida@kidconco.com	
	E & E Bravo Countertops	H	Maria Bravo	(704) 208-0144	edizbra@msn.com	
	Nichols Custom Builders & Design, Inc	B	Kwesi Nichols	(704) 400-6786	support@nicholscustombuildersanddesign.com	
	Reliable Solutions Construction	H	Johanna Suarez	(704) 449-3542	johanna@reliablerestorations.net	
	Armen Construction	H/YES	Victor Ariza	(704) 953-7459	armencontractors@aol.com	
	Carolina Custom Millwork	F	Jean Kamens	(704) 375-6030	jean@carolinacustommillwork.com	
Painting						
	United Painting Services	H	Leonardo Andrade	(704) 962-0563	leo@unitedpaintingservices.com	
	Nichols Custom Builders & Design, Inc	B	Kwesi Nichols	(704) 400-6786	support@nicholscustombuildersanddesign.com	
	Starlight Painting Contractors	H	Marvin Reyes	(704) 453-1441	marvinhreyes@gmail.com	marvin.reyes@starlightpaintingnc.com
	Bobby's Painting	B	Tay Brooks	(704) 394-5124	bobbyspaint@bellsouth.net	
	The AZ Group Contractors	H	Asael Ramos	(980) 207-4561	theazgroup3@aol.com	
	Painting The Carolinas	F	Charleen Goolsby	(704) 827-0210	linda@paintingthecarolinas.com	info@paintingthecarolinas.com
	Mecklenburg Paint Company	F	Liz Etheredge	(704) 944-1641	liz@meckpaint.com	david@meckpaint.com
	Southern Paint & Waterproofing	F/YES	Jane Douth	(336) 378-1103	jane@spwcinc.com	
	ASKI Services Company	B	Miranda Moore	(980) 226-8307	askiservicesus@gmail.com	
	Armen Construction	H/YES	Victor Ariza	(704) 953-7459	armencontractors@aol.com	
	NJR Construction LLC	B	Edward Roper	(704) 258-1531	edroper.njrconstruction@gmail.com	
	Diamond Touch Construction	B	Andrea Pettitt	(919) 787-3838	officemanager@diamondtouch.net	aly@diamondtouch.net
	NC Interiors Contracting	H	Nancy Palacios	(704) 529-0140	nancy@ncinteriorcontracting.com	
	Piedmont Stucco	H	Faye Fenske	(704) 504-1313	piedmontstucco.estimating@gmail.com	
	Regional Construction Corp	B	Orlando McClean	(704) 426-3701	orlandoamcclean@gmail.com	

2021 HUB Contractors List (Master)

	Karma Contracting	B/YES	Karim Razzak	(336) 757-6984	karmacontractinginc@gmail.com	
	Boller Logistics, LLC	B/YES	Kaylen Boller	(704) 905-9817	kbollerlogistics@gmail.com	bollertransport@gmail.com
Pavers						
	A. M. Unit Pavers, LLC	F	Angela Michaud	(704) 309-4469	ampavers@gmail.com	
Plumbing						
	Caryl Mechanicals Inc dba The Boswell Group	F/YES	Libby Caryl	(704) 289-8986	lcaryl@theboswellgroup.com	
	Reliable Insulation Enterprises	F	Vernie Pettit	(704) 732-8444	vernie@reliableinsulation.net	
	Unitary Systems	F/YES	Elaine Avery	(919) 400-5902	eavery@unitarysystems.com	
	FM Supplies	B	fassil Mitiku	(336) 391-8653	fmitiku@triad.rr.com	
	GP Supply Company	B	Antonio Wallace	(336) 274-7615	awallace@gpsupplycompany.com	david@gpsupplycompany.com
	Guilford Plumbing Supply, Inc	F/YES	Brad Yates	(336) 274-3761	byates@guilfordplumbingsupply.com	smccraw@guilfordplumbingsupply.com
	Burris Plumbing	B/YES	Brenda Burris	(704) 510-2123	burrisplumbinginc@gmail.com	
	A1 Quality, Inc	I	Christy Senior	(704) 331-9294	seniorc@bellsouth.net	
	Quate Industrial	F	Rusty Quate	(919) 596-5963	rquate@quateindustrial.com	
	Eastern Power Technologies	F	Shelby Jones	(704) 200-3645	shelby.jones@easternfirst.com	
	The Barr Group of Nashville, Inc.	F	James Murray	(615) 574-7176	james@barrgroupinc.com	
	Wallace Mechanical Supply	B	Wallace Funderburk	(843) 537-4277	inc_wallace@bellsouth.net	
	Chavis' Inc	AI	Fitzgerald Chavis	(910) 844-2000	fitz.chavis@chavisinc.com	
Portable Toilets	No Firms Identified At This Time					
Pre-Engineered Structures						
	DWS Steel Structures, Inc.	F	Marie Anderson	(336) 996-0500	marie@dws-structures.com	
Roofing						
	Radco Construction Services	F	Jann Rademacher	(704) 392-0850	radcobd@radcoconstruction.com	radcoestimating@radcoroofing.com
	Rescue Construction Solutions, Inc	B/YES	Patti Celestini	(919) 615-1759	pcelestini@rescue-cs.com	
	Pierce Roofing Supplies	F	Patricia Warf	(704) 489-0716	piercerooftingsupplies@gmail.com	
	DWS Steel Structures, Inc.	F	Marie Anderson	(336) 996-0500	marie@dws-structures.com	
	Rike Roofing Services	F	Allen Hughes	(704) 651-1969	allen@rikeroofing.com	
	KIG Construction & Building Materials	B	Kenneth Gaut	(704) 222-8422	kigconstruction2013@gmail.com	

2021 HUB Contractors List (Master)

Security & Safety						
	SAF Technologies	F	Alison Weeks	(704) 844-0955	alison.parrish@saftechnologies.com	alan.weeks@saftechnologies.com
	M-W Electric	AI	Kimberly Woods	(910) 843-9811	kwoods@mwec.biz	
Signage						
	Richa Graphics	A	Kathryn Rohera	(704) 331-9744	northend@richa.com	
	Ground Effects	F	Lynn Pressley	(704) 821-9552	gndeff1@aol.com	
	AOA Signs	F	Joy Kay	(336) 679-3344	joyk@aoasigns.com	
	Fastsigns of Mooresville	AA	Div Bhingradia	(704) 360-3805	div.bhingradia@fastsigns.com	
	Precision Signs	F/YES	Laurie Peach	(919) 615-0979	LauriePeach@precisionsignsnc.com	
	Fastsigns	F	Angela Riddle	(336) 887-2923	angela.riddle@fastsigns.com	
	RA Signs Inc	B	Roz-Kareem Jackson	(704) 890-4247	info@rasigns.com	
Site Work						
	Pedulla Excavating & Paving	F	Dominick Pedulla	(704) 663-0017	dominick@pedullaexcavating.com	
	Locke-Lane Construction Inc	D	Andrew Sherrill	(704) 585-6625	dsherrill@lockelaneconstruction.com	
	Siteworks	F	Melissa Bovit	(704) 588-3055	mbovit@siteworks-llc.com	
	Black Contracting	F/YES	Lois Black	(704) 694-3200	blackcontracting@hotmail.com	
	Rumburg Grading	F	David Rumburg	(336) 595-8830	rumburggrading@earthlink.net	
	Page and Associates Inc.	F	Mary Jane Scotte	(336) 996-5013	mjscott.pa@triadbiz.rr.com	
	Mid Atlantic Erosion Control, Inc	AA	Catherine Fowler	(704) 483-1100	maerosion@yahoo.com	
	Oliver Paving	F	Ruth Oliver	(704) 392-2462	oliver@oliverpaving.com	
	Dakota Contracting Company	AI	Mike Starkey	(704) 588-5567	mike@dakotaco.com	
	L.T. Hedrick Construction Co dba Hendrick Grading & Paving	F	Tammy Hedrick	(336) 746-5115	tammy@lthedrick.com	
	Mugo Gravel & Grading, Inc.	F/YES	Kay Christy	(704) 782-3478	kchristy@mugoinc.com	wcranford@mugoinc.com
	Redstone Materials Inc	AA	Radik Ruvim	(704) 960-9462	office@redstonematerials.com	
	Vistabution, LLC	B	Clarence Mann	(877) 288-9656	cmann45@bellsouth.net	
	Clement Construction Corporation	B/YES	Phillip Clement Sr.	(336) 661-2488	clementconst@yahoo.com	
	Double D Construction Services, Inc.	F/YES	Tracy Doub	(336) 922-4126	ddtrucking@triad.twcbc.com	sstanley@triad.twcbc.com
	Elevated Environmental Corporation	F/YES	Stephanie Gower	(800) 718-7144	info@elevatedenvironmental.com	
	Bailey Contracting, Inc	B/YES	Herbert Bailey	(919) 469-9929	kim@baileycontracting.net	
Steel & Misc Metals Fabrication						
	Gastonia Iron Works	F/YES	Katherine Pace	(704) 827-1146	giw@gastoniaironworks.com	
	National Erectors Rebar	I	Jeffery Jones	(910) 618-9200	mlocklearne@yahoo.com	
	Adriana Lopez dba Lopez Rebar	H/YES	adriana Lopez	(704) 707-7921	itonylopez2010@hotmail.com	
	Threadline Products	F	Lenore Lemmond	(704) 527-9052	lenore@threadlineproducts.com	

2021 HUB Contractors List (Master)

	Carolina Fab	F	Debbie Evans	(704) 820-8694	devans@carolinafabinc.com	
	Commercial Fabricators	I	Richard Tucker	(828) 465-1010	nelliott@commfab.com	
	Carolina Structural Welding & Steel	H	Aurelia Chacon	(980) 307-1706	achacon@carolinasw-inc.com	
	Custom Sheetmetal Services	F/YES	Peggy Lee	(919) 282-1070	leep@custom-sheetmetal.com	
	Structural Steel of Carolina, LLC	F	Michael Parnell	(336) 354-4159	mparnell@steelofcarolina.com	
	W & W Crane and Rigging	F/YES	Daniel Lizotte	(336) 442-0167	dlizotte@wandwcrane.com	
	Ogeechee Steel, Inc.	I	Janet Johnson	(478) 237-2770	bperossa@ogeecheesteel.com	
	L & L Metals, Inc.	B	Lynn Cauthen	(704) 372-9458	lynn@landlmetals.com	
	M&C Investments dba Cochrane Steel	F	Brian Hartis	(704) 291-9330	brian@cochranesteelusa.com	
	Border Rebar	H/YES	Bruce Rangel	(704) 675-5313	bruce@borderrebar.com	
Striping						
	James Seals & Stripes	F/YES	Jeannie Reid	(704) 202-0404	jeannie@jss-inc.com	
	Luvall Asphalt Services	B	Donald Britten	(980) 256-2807	luvallasphaltservices@gmail.com	paving@luvallasphaltservices.com
Telecommunications						
	Network Cabling Systems	H/YES	Louis Romero	(704) 523-8606	elizabeth@networkcablingsystems.com	max@networkcablingsystems.com
	Innovative Security Solutions	B	Ronard Dixon	(704) 376-3353	rcdixonsr@issolutions.net	
	Protech Systems an NBS Technology Company	B	Phanuel Nueman	(704) 296-2894	phan@nbstechnology.com	
	AJT Technology Designs, Inc.	B	Todd Hill	(630) 447-9896	todd.hill@ajttechnology.com	
	C2 Contractors, LLC	B/YES	Ursula Williams	(336) 669-4450	ursula@c2contractorsllc.com	
Temporary Labor Services						
	ProCon Staffing	F	Cindy Brock	(888) 519-0347	clbrock@procstaff.com	
	Harris Ventures, Inc. dba Staff Zone	F	Sherri Harris	(770) 645-6134	cdeluca@thestaffzone.com	
	Access Services	B/YES	Kevin Smith	(704) 644-5529	kevin@access-services.biz	frank@access-services.biz
Test & Balance						
	Mullinax TAB, Inc	F	Ed Mullinax	(864) 649-1091	ed@mtabinc.com	
	Palmetto Air & Water Balance	F/YES	Penny Hinton	(704) 587-7073	phinton@palmettoairbalance.com	
	Airflow Experts	F	Candy Clarke	(888) 229-1477	candyclarke@airflowexperts.com	
Toilet Particions & Accessories						
	Southern Door Supply Co, Inc.	F/YES	Kathleen Fennell	(704) 332-4460	kfennell@southerndoorsupply.com	
	Stuart Page Company, Inc	F	Kim Page	(704) 545-0695	kim@stuartpagecompany.com	

2021 HUB Contractors List (Master)

Traffic Control						
	Roadmasters Traffic Control LLC	F/YES	Amanda Huffman	(704) 585-9635	roadmasterstc@att.net	
	Ground Effects, Inc.	F	Lynn Pressley	(704) 821-9552	GNDEFF1@aol.com	
Utilities						
	M-W Electric	AI	Kimberly Woods	(910) 843-9811	kwoods@mwec.biz	
	Calamar, Inc.	F	Pamela Lane	(919) 969-1574	planep1@aol.com	
	Locke-Lane Construction Inc	D	Andrew Sherrill	(704) 585-6625	dsherrill@lockelaneconstruction.com	
	AMP Utility Distribution Services	F	Alleyne Pool	(704) 248-8100	amputility@aol.com	
	Dakota Contracting Company	AI	Mike Starkey	(704) 588-5567	mike@dakotaco.com	
Waterproofing/Air Barrier/Joint Sealants/Thermal & Moisture Protection						
	Taylor Interiors, LLC	B/YES	Tarris Arnold	(704) 886-4813	taylorinteriorsllc@yahoo.com	
	Waterproofing Specialties	H	Tamara Guilliams	(704) 489-2099	tamig@wsi-nc.com	
	Melco & Associates	H	Melissa Alejandro	(704) 348-4588	melissa@melcofirestopping.com	
	A1 Quality Inc	AI	Kenny White	(704) 331-9294	seniorc@bellsouth.net	
	Triangle Caulking & Waterproof	F	Gwen Macdonald	(919) 556-2983	trianglecaulk@aol.com	
	Elevated Environmental Corporation	F/YES	Stephanie Gower	(800) 718-7144	info@elevatedenvironmental.com	
	Southern Paint & Waterproofing	F/YES	Jane Doult	(336) 378-1103	jane@spwcinc.com	
Window Treatments						
	Contract Window Treatments Inc	F	Sharon Segall	(336) 299-1091	sharon@contractwindowtreatmentsinc.com	
	Express Blinds	F	Wanda Bradley	(704) 881-2398	expressblindservice@gmail.com	
	TPS Investments dba The Original Blindman	F/YES	Debra Garland	(704) 454-7040	theblindmanoffice@vnet.net	theblindman@vnet.net