



## Addendum

ADDENDUM NO.: 1 DATE: 3/31/2021

PROJECT TITLE: Fretwell Café Renovations  
University of North Carolina Charlotte  
SCO ID# 19-21437-01A  
WTS Project No. 2007

WRITTEN BY: Jana Hartenstine/Joe Hiestand

TO: Prospective Bidders / Plan Holders/ PreBid Attendees

---

This addendum is issued pursuant to the University of North Carolina General Administration Instructions to Bidders and General Conditions of the Contract in connection with the revision of Bidding Documents which have been previously issued.

Addenda are issued prior to execution of Contract. All instructions contained herein shall be reflected in the Contract Sum and this Addendum will be made a part of the Contract Documents, if, as, and when a Construction Contract is awarded.

This Addendum forms a part of the Contract Documents and modifies the original documents dated March 18, 2021, as noted below. Acknowledge receipt of this Addendum in this space provided on the Form of Proposal. Failure to do so will subject the Bidder to disqualification.

This Addendum consists of 29 pages and '0' 30X42 SHEET attachments.

### **A. REVISIONS TO THE PROJECT MANUAL:**

1. Revise the project manual by adding the following forms:
  1. Add the attached UNC Charlotte Good Faith Requirements
  2. Form of Bid Bond
2. Revise the project manual as follows:
  - A. Table of Contents: Add the following list of forms to the Table of Contents after 001115 and before DIVISION 01:
    1. UNC CHARLOTTE GOOD FAITH EFFORT REQUIREMENTS

### **B. REVISIONS TO DRAWINGS:**

1. THE FOLLOWING FULL-SIZE SHEETS ARE RE-ISSUED:
  - A. There are no reissued drawings in this Addendum.

**C. BIDDER CLARIFICATION REQUESTS**

RFI's to be emailed to [jhartenstine@watsontatesavory.com](mailto:jhartenstine@watsontatesavory.com):

All questions shall be submitted by 5:00 pm 4/01/2021. Bidders shall expect a confirmation of receipt by WTS within 12 hours and if not, shall follow up to verify email was received.

1. There are no Bidder Clarification Requests issued in this Addendum.

**D. SUBSTITUTION REQUESTS**

Signed substitution forms have been attached to this addendum. All substitution requests are to be submitted by General Contractors for consideration.

#	SPECIFICATION/PROJECT MANUAL REFERENCE	ACCEPTABLE PRODUCTS	
SR-01	09 5113 ACOUSTIC BAFFLE CEILING TILE	J2 PET FELT ACOUSTIC DROP-IN BAFFLE TILE	Accepted
SR-02	09 5113 ACOUSTIC BAFFLE CEILING TILE	SOUNDCORE GRID BLADES ACOUSTIC CEILING TILES	Accepted

**E. ADDITIONAL CLARIFICATIONS**

1. Topic: Fretwell Hall – Prebid  
Date: March 29, 2021 2:00 PM Eastern Time (US and Canada)

**Meeting Recording:**

<https://watsontatesavory.sharefile.com/d-sbcc8693f726747518aaa3557f4ec4a13>

PRE-BID ATTENDEE LIST IS ATTACHED.

2. A link is included below to download original Fretwell Hall Construction Drawings from 1994 provided by UNC Charlotte. These are for reference only, and not a part of the contract documents.

<https://watsontatesavory.sharefile.com/d-sb928c29970c546bcb3dab2bd69c323d8>

END OF ADDENDUM 1

**UNC Charlotte**  
**“Good Faith Effort” Requirements - UMP**  
**(Fretwell Café)**

This information is provided as a guide for firms who may be new to UNC Charlotte and may not be familiar with our expectations regarding minority business participation on University Managed Projects (UMP) projects. Bidders should be familiar with the ***Guidelines for Recruitment & Selection of Minority Businesses for Participation in University of North Carolina Construction Contracts***

The minority participation goal for this project is ten percent (10%).

**Identification of HUB Certified/Minority Business Participation form** – Only list minority firms that you will use as construction subcontractors, vendors, suppliers or professional service providers on this project. The bidder cannot list himself on this form as he cannot subcontract to himself. **Note:** This form should be submitted with your bid, even if left blank.

**Affidavit A – Listing of Good Faith Efforts** – the bidder is certifying that he has made a good faith effort to comply under those areas checked on the form. Do not check a Good Faith Effort item unless you can provide the following;

1. Contacting minority businesses that reasonably could have been expected to submit a quote and that were known to the contractor or available on State or local government-maintained lists **at least 10 days before the bid or proposal date** and notifying them of the nature and scope of the work to be performed.  
**Example:** Copies of written (emailed or faxed) notification to minority businesses and copies of quotes/proposals received for work solicited to minority businesses. Notification should include, at a minimum, project location, location where plans and specifications may be obtained or viewed, trade or scopes of work for which subcontracts are being solicited, contact person within the prime contractor organization.

***Be sure to maintain a telephone log to confirm that minority firms received your Invitation for Bid (IFB).*** The log should contain the date contacted, telephone number, and name of the individual representing the minority firm who acknowledged receipt of your IFB. ***Also maintain a telephone log to confirm that minority firms acknowledged a “bid/no bid” to your IFB.*** The log should contain the date contacted, telephone number, and name of the individual representing the minority firm who acknowledged “bid/no bid” to your IFB.

2. Making the construction plans, specifications and requirements available for review by prospective minority businesses, or providing these documents to them at least 10 days before the bid or proposals are due.  
Copies of written (emailed or faxed) notification to minority businesses should include, at a minimum, project location, location where plans and specifications may be obtained or viewed, trade or scopes of work for which subcontracts are being solicited, contact person within the prime contractor organization.
3. Breaking down or combining elements of work into economically feasible units to facilitate minority participation.  
Document steps taken to segment elements of work into economically feasible units to meet minority business availability. Identify sub-contractors/suppliers/consultants and scope of work involved in segmenting.

Be sure that you are soliciting quotes from **at least** three (3) minority firms in scopes of work that typically have adequate numbers of minority firms available that can perform the work required (hauling, concrete, flooring, masonry, painting, electrical suppliers, etc.). Do not solicit quotes from minority firms in those scopes of work that typically do not have minority firms available that can perform the work

required (elevators, fire suppression systems, roofing, etc.). If there are minority firms that you typically use on your projects then by all means, feel free to use them, if you are sure you are receiving reasonable pricing and quality work.

4. Working with minority trade, community or contractor organization identified by the Office for Historically Underutilized Businesses (HUB) and included in the bid documents that provide assistance in the recruitment of minority businesses. **Note 1:** Posting of your bid to Minority plan rooms does not satisfy this requirement. **Note 2:** Working with the UNC Charlotte HUB Coordinator does not satisfy this requirement.

Provide a copy of meeting minutes between prime contractor and minority trade, community or contractor organization. At minimum the following topics should be discussed/reviewed during the meeting: project location; location where plans and specifications may be obtained or viewed; trade or scopes of work for which subcontracts are being solicited; bonding requirements; insurance requirements; prime contractor's contact person; minority trade, community or contractor organization contact person; strategies to segment elements of the work into economically feasible units to meet minority business availability; strategies to increase minority business utilization through joint ventures and/or partnerships; notification that the meeting will be counted toward the contractor's good faith effort.

Maintain a copy of the request, and have the date, telephone number and name of the individual who acknowledged receipt of your request and information regarding any/all assistance provided by the organization

5. Attending any pre-bid meetings scheduled by the public owner.  
Attendance will be verified by conference sign-in sheet.
6. Providing assistance in getting required bonding or insurance or providing alternatives to bonding or insurance for subcontractors.  
Have documentation describing the type of assistance provided or offered to minority businesses. Provide names and contacts of minority businesses to which assistance was offered and names of the contact person of bonding companies or financial institutions offering assistance.  
**Be sure to mention that 'assistance with bonding and/or insurance will be provided'** in your IFB.
7. Negotiating in good faith with interested minority businesses and not rejecting them as unqualified without sound reasons based on their capabilities. Any rejection of a minority business based on lack of qualification should have the reasons documented in writing.  
Document number of bids received from minority businesses in the trade or scopes of work for which subcontracts are being solicited, the number of minority businesses that submitted low bids or proposals, the number of minority businesses the bidder has offered to negotiate prices or services, and the number of minority businesses the bidder has agreed to utilize on the project, outline steps taken.
8. Providing assistance to an otherwise qualified minority business in need of equipment, loan capital, lines of credit, or joint pay agreements to secure loans, supplies, or letters of credit, including waiving credit that is ordinarily required or assisting minority businesses in obtaining the same unit pricing with the bidder's supplier.  
Document names, addresses and telephone numbers of minority businesses to which assistance was offered, outline steps taken. Give dates assistance was offered and document outcome.  
**Be sure to mention that 'assistance with equipment, loan capital, lines of credit or joint pay agreements to secure loans, supplies, or letters of credit will be provided'** in your IFB.
9. Negotiating joint venture and partnership arrangements with minority businesses in order to increase opportunities for minority business participation on a public construction or repair project when possible.

Provide a copy of joint venture or partnership arrangements between bidder and minority businesses.

10. Providing quick pay agreements and policies to enable minority contractors and suppliers to meet cash-flow demands.

**Be sure to mention that 'quick pay agreements will be provided to assist contractors with cash-flow demands' in your IFB.** Do not include stipulations that require the contractor to prove they need the quick pay.

Provide a copy of quick pay agreements and/or policies and document the number of minority businesses that will utilize the quick pay agreement. Provide a copy of the quick pay agreement between bidder and minority businesses.

Net 30 or 45 is not quick pay.

**Quick Pay will be paid whether or not the General Contractor has been paid or the Owner has approved the minority subcontractor's work.**

**Note: Referencing the Good Faith Efforts listed above in your IFB is not enough. You must be able to document your efforts.**

**Affidavit B – Intent to Perform Contract with Own Workforce** – In making this certification the bidder is stating that he does not customarily subcontract elements of this type project and normally performs and has the capability to perform and will perform all elements of the work on this project with his own current workforce. The bidder agrees to make a Good Faith Effort to utilize minority suppliers where possible. **“Self-performing”** means the contractor has all equipment, personnel and supplies on hand to perform the contract. If the contractor needs to purchase supplies or rent equipment and operators to perform the work, then the contractor **is not** self-performing and should make efforts to purchase supplies or equipment, or temporary labor from minority firms. **Note:** No other Affidavits are required if the Bidder meets this criteria.

**Affidavit C – Portion of the Work to be Performed by HUB Certified/Minority Businesses** – This form is to be submitted only by the apparent lowest responsible, responsive bidder with equal to or greater than 10% minority participation.

**Affidavit D – Good Faith Efforts** – This form is to be submitted only by the apparent lowest responsible, responsive bidder with less than 10% minority participation along with their backup documentation.

**Minority-owned Pre-qualified Bidders** – **must also** meet the minority participation goals set for the project. Work performed by the minority-owned pre-qualified bidder will be counted towards the minority participation goal **only if** the minority contractor is **self-performing** and submitted Affidavit B.

**Certification Requirements** – Ensure the minority firms you contact for subcontracting opportunities are listed in the Statewide Uniform Certification (SWUC) Vendor database as **only firms** listed in the SWUC Vendor database, at the time of contract award, **will be counted** towards the minority participation goal for this project. Go to <https://www.ips.state.nc.us/Vendor/searchvendor.aspx?t=h> for access to the SWUC Vendor database.

#### **Assistance:**

**Email the UNC Charlotte HUB Coordinator, Dorothy Vick (704-687-0527), no later than 12:00 Noon, Thursday, April 1, 2021** to [dlvick@uncc.edu](mailto:dlvick@uncc.edu) (**Email Subject: Fretwell Café**) for the following;

1. **Assistance in finding certified minority firms who have worked on UNC Charlotte projects and who can perform the scopes of work (site work, concrete, electrical, etc.) you are seeking, and/or**
2. **A list of minority trade, community or contractor organizations** identified by the Office for Historically Underutilized Businesses that provide assistance in the recruitment of minority businesses.

**FORM OF BID BOND**

KNOW ALL MEN BY THESE PRESENTS THAT \_\_\_\_\_

\_\_\_\_\_ as principal, and \_\_\_\_\_, as surety, who is duly licensed to act as surety in North Carolina, are held and firmly bound unto the State of North Carolina\* through \_\_\_\_\_ as obligee, in the penal sum of \_\_\_\_\_ DOLLARS, lawful money of the United States of America, for the payment of which, well and truly to be made, we bind ourselves, our heirs, executors, administrators, successors and assigns, jointly and severally, firmly by these presents.

Signed, sealed and dated this \_\_\_\_ day of \_\_\_\_ 20\_\_

WHEREAS, the said principal is herewith submitting proposal for and the principal desires to file this bid bond in lieu of making the cash deposit as required by G.S. 143-129.

NOW, THEREFORE, THE CONDITION OF THE ABOVE OBLIGATION is such, that if the principal shall be awarded the contract for which the bid is submitted and shall execute the contract and give bond for the faithful performance thereof within ten days after the award of same to the principal, then this obligation shall be null and void; but if the principal fails to so execute such contract and give performance bond as required by G.S. 143-129, the surety shall, upon demand, forthwith pay to the obligee the amount set forth in the first paragraph hereof. Provided further, that the bid may be withdrawn as provided by G.S. 143-129.1

\_\_\_\_\_(SEAL)

\_\_\_\_\_(SEAL)

\_\_\_\_\_(SEAL)

\_\_\_\_\_(SEAL)

\_\_\_\_\_(SEAL)

\*(Community college projects: Delete State of North Carolina as owner and replace with community college name.)



# SUBSTITUTION REQUEST

(During the Bidding/Negotiating Stage)

Project: Fretwell Cafe Renovations

Substitution Request Number: \_\_\_\_\_

To: Watson Tate Savary

From: J2 Systems

Date: 3/25/21

Re: Jana Hartenstine

A/E Project Number: \_\_\_\_\_

Contract For: \_\_\_\_\_

Specification Title: Acoustical Panel Ceilings

Description: Acoustical Baffle Ceiling Tile

Section: 095113 Page: 3

Article/Paragraph: 2.5

Proposed Substitution: J2 PET Felt Acoustic Drop-In Baffle Tile

Manufacturer: J2 Systems Address: SLC, UT

Trade Name: \_\_\_\_\_ Phone: 801-701-7979

Model No.: \_\_\_\_\_

Attached data includes product description, specifications, drawings, photographs, and performance and test data adequate for evaluation of the request; applicable portions of the data are clearly identified.

Attached data also includes a description of changes to the Contract Documents that the proposed substitution will require for its proper installation.

The Undersigned certifies:

- Proposed substitution has been fully investigated and determined to be equal or superior in all respects to specified product.
- Same warranty will be furnished for proposed substitution as for specified product.
- Same maintenance service and source of replacement parts, as applicable, is available.
- Proposed substitution will have no adverse effect on other trades and will not affect or delay progress schedule.
- Proposed substitution does not affect dimensions and functional clearances.
- Payment will be made for changes to building design, including A/E design, detailing, and construction costs caused by the substitution.

Submitted by: Shandelle Carpenter

Signed by: J2 Systems

Firm: J2 Systems

Address: 1750 S. 500 W. #300  
SLC, UT 84115

Telephone: 801-701-7979

### A/E's REVIEW AND ACTION

- Substitution approved - Make submittals in accordance with Specification Section 01 25 00 Substitution Procedures.
- Substitution approved as noted - Make submittals in accordance with Specification Section 01 25 00 Substitution Procedures.
- Substitution rejected - Use specified materials.
- Substitution Request received too late - Use specified materials.

Signed by: JANA HARTENSTINE, AIA Date: 3.31.2021

Supporting Data Attached:  Drawings  Product Data  Samples  Tests  Reports  \_\_\_\_\_



# J2 PET Acoustic Felt

## PRODUCT DATA AND SPECIFICATIONS



J2 PET Acoustic Felt panels provide excellent sound absorption without compromising on aesthetic function. Panels can be cut in any shape or size to accommodate design specifications. Our panels are eco-friendly, as they are made from recycled material. J2 PET Acoustic Felt panels are lightweight, durable, hard-wearing and tackable. We offer these panels in 28 color options.

### Composition

100% PET (>75% recycled PET material)

### Thickness

9mm, 12mm, other custom thicknesses available

### Density

1900g/sqm-2400g/sqm (approx 14pcf)

### Dimensions

Standard Panel 4' x 8'

### Fire Rating

ASTM E84 - Class B (Class A panels available on request, color options may vary)  
EN13501 - Class B

### Acoustic NRC

0.3-0.9 Depending on thickness and airgap

### Application

Screen, wall, and ceiling panels

### Material Notes

Variation in thickness, fiber mix and color, as well as flecks and other slight surface blemishes are an inherent feature of this product and are unavoidable. Variation from batch to batch may occur.

### Cleaning and Care

Remove dust and dirt by dusting, vacuuming, or with a soft cloth or sponge and a solution of carpet or upholstery shampoo. Use a soft, damp cloth and blot dry. Spot cleaner can be used for lightly soiled areas.

### Mounting Options

Panels can be installed on wall and ceiling surfaces via fasteners, or standard construction adhesives. When installing with adhesives, the panels can be mounted directly to the surface, or furring strips can be installed to create an air gap behind the panels.

### Warranty

2-year warranty against workmanship and manufacturing defects.

### 12mm PET Acoustic Felt NRC Comparison:

Frequency/Hz	100	125	160	200	250	315	400	500	630	800	1000	1250	1600	2000	2500	3150	4000	NRC
No Cavity	0.03	0.01	0.06	0.04	0.03	0.09	0.11	0.23	0.28	0.40	0.49	0.61	0.69	0.76	0.84	0.90	0.90	0.4
50mm / 2in	0.16	0.16	0.19	0.29	0.38	0.48	0.61	0.75	0.83	0.97	0.97	0.93	0.96	0.91	0.86	0.83	0.89	0.75
150mm / 6in	0.26	0.37	0.41	0.62	0.68	0.82	0.89	0.98	0.90	0.92	0.81	0.75	0.82	0.87	0.87	0.90	0.90	0.85

# J2 PET Felt Color Chart

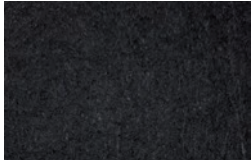

Black - 27

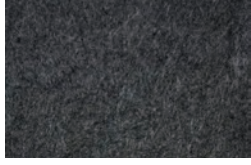

Dark Gray - 28



Sesame Gray - 26

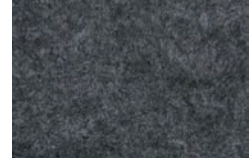

Gray - 25



Medium Gray - 12



Light Gray - 11

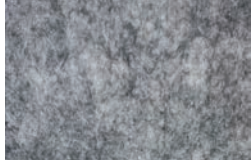

Dark Marble - 35



Marble Gray - 10



White - 04

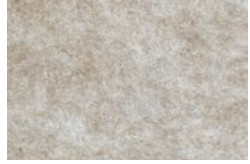

Light Camel - 05

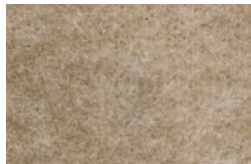

Dark Camel - 06



Yellow - 02



Orange - 03



Red - 17



Wine - 18



Violet - 19



Midnight Blue - 16



Deep Blue - 23



Deep Sky Blue - 33



Sky Blue - 22



Blue - 36



Lake Blue - 37

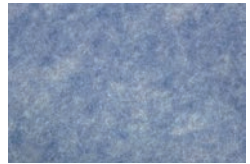

Light Blue - 21



Aqua - 38

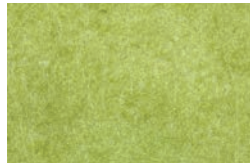

Apple Green - 13



Bright Green - 14



Turquoise - 39

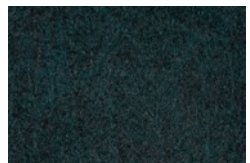

Deep Green - 34

*Custom colors available upon request. Minimum order quantities apply.*

# J2 PET Felt Acoustic Drop-In Baffle Tile

## PRODUCT DATA AND SPECIFICATIONS

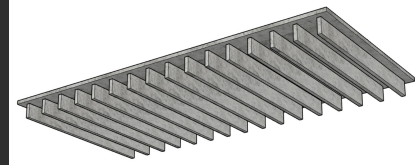

With J2 PET Felt Acoustic Drop-In Baffle Tiles, drop-in ceilings can make a bold aesthetic statement. Designed to fit into standard 2'x2' and 2'x4' ceiling grids, installation is simple and familiar. Our drop-in ceiling tiles are made from J2 PET Acoustic Felt, which is composed of >75% recycled material, so they are an eco-friendly choice. These tiles are available in 24 color options.

<b>Style</b>	Drop-in Ceiling Tile
<b>Composition</b>	100% PET (>75% recycled PET material)
<b>Thickness</b>	12mm
<b>Density</b>	1900g/sqm-2400g/sqm (approx 14pcf)
<b>Dimensions</b>	2x2: 23.69in x 23.69in x 2.5in, 2x4: 23.69in x 47.69in x 2.5in (custom blade heights are available)
<b>Fire Rating</b>	ASTM E84 - Class B (Class A panels available on request)
<b>Acoustic NRC</b>	All acoustic panel systems offer diverse sound absorption characteristics. Similar cloud systems have an NRC of between 0.65-0.90, however not all systems have been tested for NRC ratings.
<b>Application</b>	Drop-in or direct ceiling mount
<b>Hardware and Installation</b>	Tiles are provided in 2x2 or 2x4 formats, and can be placed in standard 9/16in and 15/16in t-grid ceilings. Ceiling grid hardware is not included. Some assembly of the individual ceiling tiles is required.

### Product Diagram:

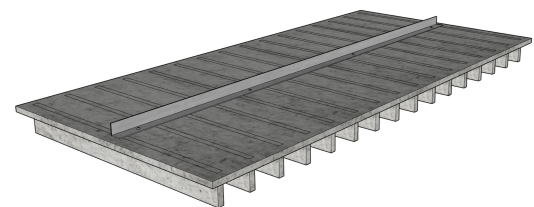
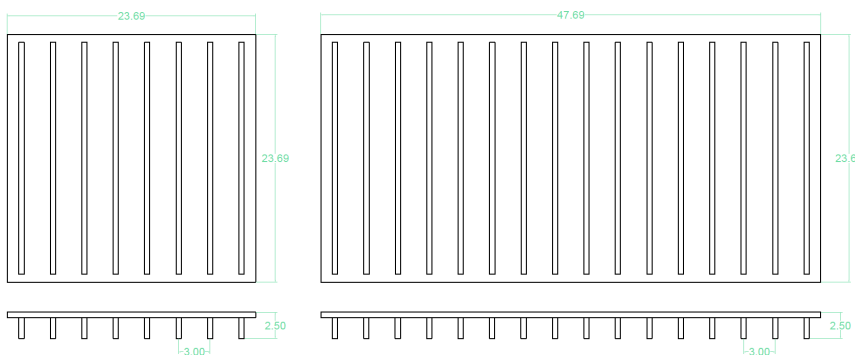

 [www.j2systems.net](http://www.j2systems.net)

 [sales@j2systems.net](mailto:sales@j2systems.net)

 (801) 701-7979

 1750 S 500 W, Ste 300  
Salt Lake City, UT 84115

**CSI Form 1.5C**

**SUBSTITUTION  
REQUEST  
(During the Bid Period)**

Project: \_\_\_\_\_ Substitution Request Number: \_\_\_\_\_  
\_\_\_\_\_  
From: \_\_\_\_\_  
To: \_\_\_\_\_ Date: \_\_\_\_\_  
\_\_\_\_\_  
A/E Project Number: \_\_\_\_\_  
Re: \_\_\_\_\_ Contract For: \_\_\_\_\_

Specification Title: \_\_\_\_\_ Description: \_\_\_\_\_  
Section: 095113 Page: \_\_\_\_\_ Article/Paragraph: \_\_\_\_\_

Proposed Substitution: \_\_\_\_\_  
Manufacturer: \_\_\_\_\_ Address: \_\_\_\_\_ Phone: \_\_\_\_\_  
Trade Name: \_\_\_\_\_ Model No.: \_\_\_\_\_

Attached data includes product description, specifications, drawings, photographs, and performance and test data adequate for evaluation of the request; applicable portions of the data are clearly identified.

Attached data also includes a description of changes to the Contract Documents that the proposed substitution will require for its proper installation.

The Undersigned certifies:

- Proposed substitution has been fully investigated and determined to be equal or superior in all respects to specified product.
- Same warranty will be furnished for proposed substitution as for specified product.
- Same maintenance service and source of replacement parts, as applicable, is available.
- Proposed substitution will have no adverse effect on other trades and will not affect or delay progress schedule.
- Proposed substitution does not affect dimensions and functional clearances.
- Payment will be made for changes to building design, including A/E design, detailing, and construction costs caused by the substitution.

Submitted by: \_\_\_\_\_

Signed by: 

Firm: \_\_\_\_\_

Address: \_\_\_\_\_

\_\_\_\_\_

Telephone: \_\_\_\_\_

**A/E's REVIEW AND ACTION**

- Substitution approved - Make submittals in accordance with Specification Section 01 25 00 Substitution Procedures.
- Substitution approved as noted - Make submittals in accordance with Specification Section 01 25 00 Substitution Procedures.
- Substitution rejected - Use specified materials.
- Substitution Request received too late - Use specified materials.

Signed by:  **JANA HARTENSTINE, AIA** Date: 3.31.2021

Supporting Data Attached:  Drawings  Product Data  Samples  Tests  Reports  \_\_\_\_\_

This is not an official CSI Construction Contract Administration (CCA) Form. Please use CSI's official CCA Forms if required by your project needs.

# GRID BLADES



# CSI SOUNDCORE® GRID BLADES

## SIDE-BY-SIDE COMPARISON

	CSI Wall Panels <b>Soundcore® Grid Blades Ceiling Tiles</b>	Unika Vaev <b>Ecoustic Sculpt™</b>
<b>Core Content:</b>	Soundcore® 100% Recycled & Virgin Polyester (PET) Acoustic Fibers	100% PET Panels with aluminum rails
<b>Dimensions:</b>	TYP 1 - 48" x 24" x 4 1/2" TYP 2 - 48" x 24" x 2 3/8" (Reference Soundcore® Grid Blades Cut Sheet, Customization Available)	Deep - 47 1/16" x 23 7/16" x 4 1/2" Shallow - 23 7/16" x 23 7/16" x 2 3/8" ----
<b>Finish Options:</b>	Soundcore® Color Group A (12mm): 21 Premier Standard Colorways Soundcore® Color Group B (9mm): 24 Premier Standard Colorways CSI Soundcore® Premier Wood Textures	Unika Vaev 15 Standard colors ---- ----
<b>Acoustic Performance:</b>	0.45 - 0.90 NRC (NRC varies by CSI Products)	Base NRC: 0.65 - 0.75 ----
<b>Attachment:</b>	Drop-in Ceiling Tile System (Compatible with 15mm (9/16") and 24mm (15/16") tee grid systems)	ecoustic Sculpt™ compatible with 9/16" and 15/16" tee grid systems ----
<b>Flammability:</b>	Class-A Fire Rated, ASTM E84	ASTM E-84 - Class A
<b>Environmental:</b>	Contributes to LEED v4 Credits, Greenguard Gold Certification, VOC free, 100% recyclable, non-toxic, non-allergenic (Test Reports Available Upon Request)	Recyclable, Low VOC, Green Star + LLEED ---- ----
<b>Manufacturer:</b>	<a href="http://www.csisoundcore.com">www.csisoundcore.com</a>	<a href="https://unikavaev.com/">https://unikavaev.com/</a>



# GRID BLADES UV005

CSI SOUNDCORE®

48" x 24" x 4 1/2"

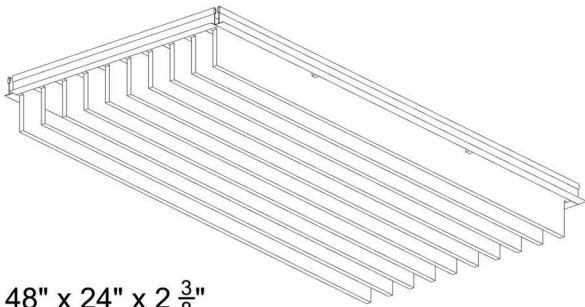

24" x 24" x 4 1/2"

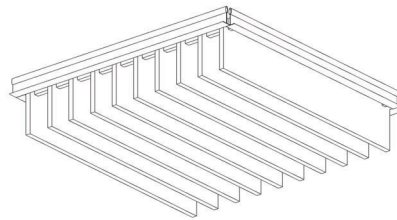

48" x 24" x 2 3/8"

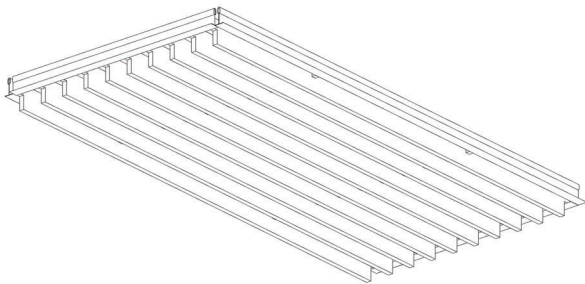

24" x 24" x 2 3/8"

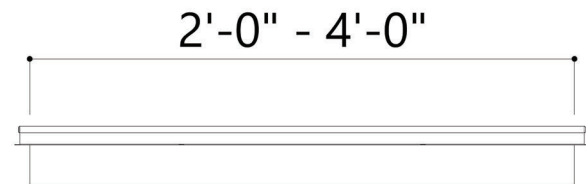
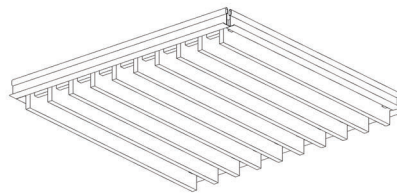

2 FRONT VIEW

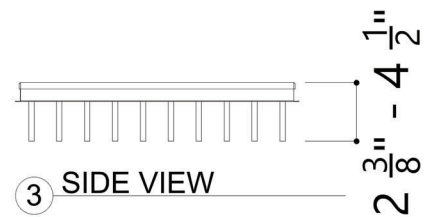

3 SIDE VIEW

1 PERSPECTIVE VIEWS

CUSTOM SIZING AND THICKNESS AVAILABLE  
CUSTOM COLORS AND DESIGNS AVAILABLE  
MULTIPLE ATTACHMENT SYSTEM OPPORTUNITIES



CSI WALL PANELS

PROJECT:

SCALED AS NOTED  
MATERIALS / COLORS

ALL DIMENSIONS + / - 1/16

DATE: 3/26/2021  
JOB #:

SHEET  
**1.1**  
OF 1.1

# GRID BLADES UV005 - ASSEMBLY

CSI SOUNDCORE®

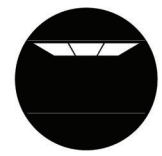

48" x 24" x 4 1/2"

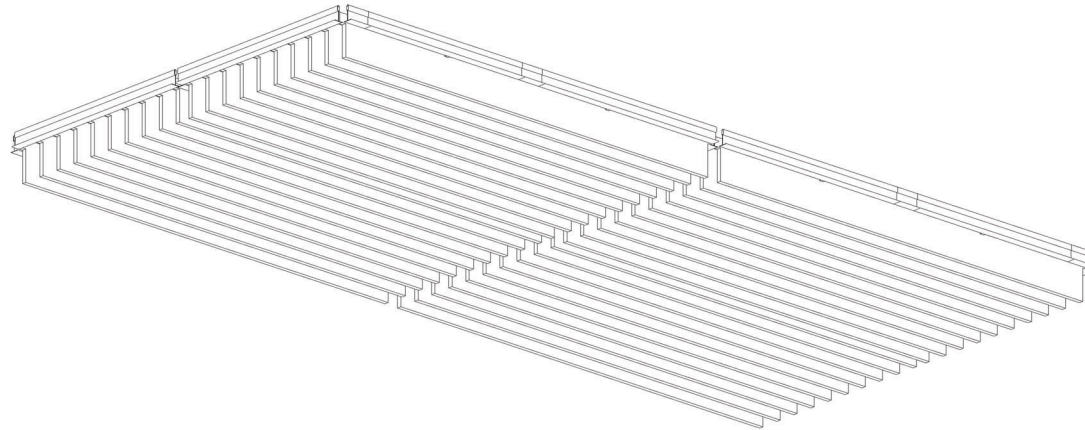

24" x 24" x 4 1/2"

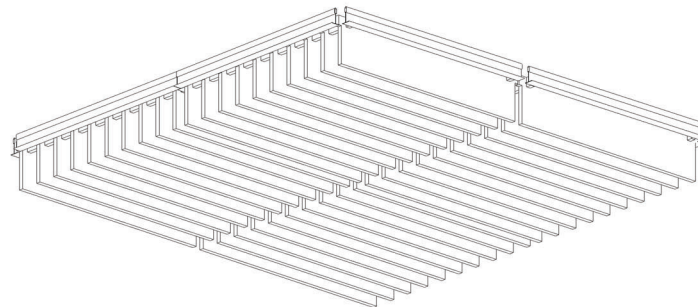

## 1 PERSPECTIVE VIEWS

CUSTOM SIZING AND THICKNESS AVAILABLE  
CUSTOM COLORS AND DESIGNS AVAILABLE  
MULTIPLE ATTACHMENT SYSTEM OPPORTUNITIES



CSI WALL PANELS

PROJECT:

SCALED AS NOTED  
MATERIALS / COLORS

ALL DIMENSIONS + / - 1/16

DATE: 3/26/2021  
JOB # :

SHEET  
**1.1**  
OF 1.1



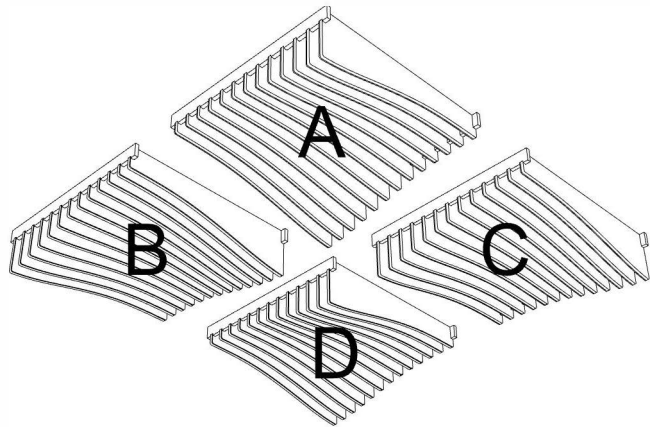
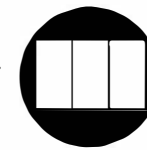

④ PERSPECTIVE COMPONENT VIEW

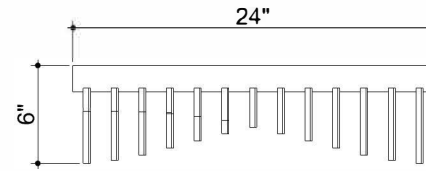

● SIDE VIEW

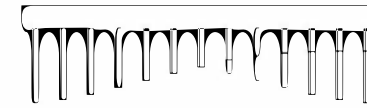

④ FRONT VIEW

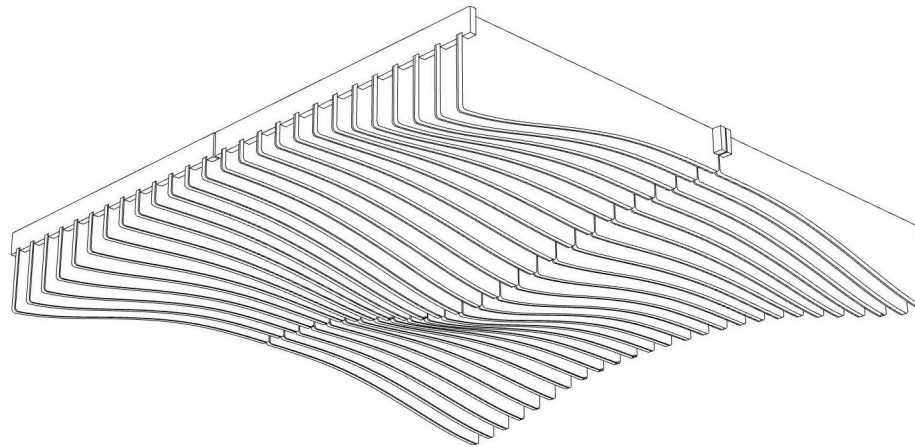
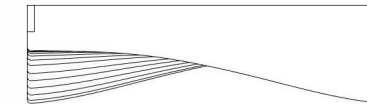

● PERSPECTIVE ASSEMBLY VIEW

CUSTOM SIZING AND THICKNESS AVAILABLE  
CUSTOM COLORS AND DESIGNS AVAILABLE  
MULTIPLE ATTACHMENT SYSTEM OPPORTUNITIES



CSI WALL PANELS

PROJECT:

SCALED AS NOTED

ALL DIMENSIONS + / -  $\frac{1}{16}$

DATE: 3/26/2021  
JOB # :

SHEET  
**1.1**  
OF 1.1

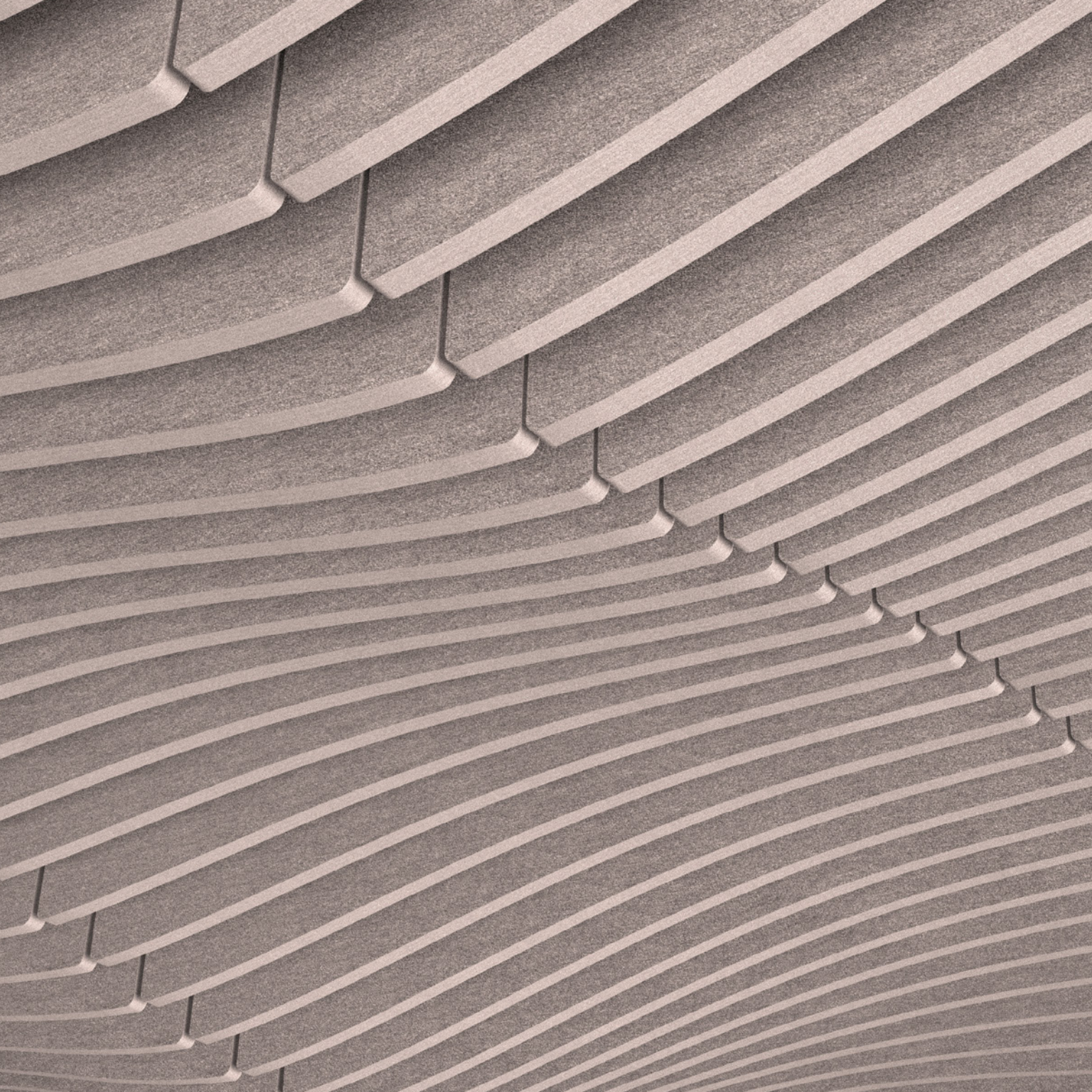



## EXPERIENCE **IMMERSION**

*“Breaking the fourth wall”* is a common way of saying something has pulled you out of an otherwise immersive experience. If something in your environment seems out of place, it distracts from the artistic intent and interrupts the narrative in which you expected to lose yourself. An encompassing, cohesive visual character fully engages the mind of an observer, sparking inspiration and creating a powerfully real experience.

# GRID

CSIPOSHFEIT®

## INTRODUCTION

In order to create truly immersive experiences, we went beyond the fourth wall, up to the ceiling. So many interiors spend huge effort in expressing their identity on the walls with cladding, artwork and signage, but ultimately leave the ceiling untouched—the dreaded plain white grid. What might have been an experiential masterpiece suddenly feels incomplete, exposed, and resembles only a suggestion of artistic intent. Our Grid collection is engineered for versatility, and optimized to fit all standard ceiling grids so you can complete your experiential masterpiece without the construction.



## SPECIFICATIONS

<b>CONTENT</b>	PoshFelt <sup>®</sup> 100% wool acoustic felt
<b>NRC RATING</b>	0.45-0.9 NRC depending on installation
<b>SIZING</b>	Custom Sizing available
<b>WEIGHT</b>	Varies by design; 0.5-1 lb / ft <sup>2</sup>
<b>COLORS</b>	39 premier colorways
<b>INSTALLATION</b>	Drop-in Tiles, CSI Magnetic Grid Attachment, Pressure Fit
<b>FIRE RATING</b>	ASTM E84, Class-A Fire Rated Available
<b>ENVIRONMENTAL</b>	Contributes to LEED v4 Credits
<b>MAINTENANCE</b>	Vacuum to remove dust Clean spills with clean damp cloth, soap, water. Mild fabric detergents. Always test on hidden areas first.



Wall Mounted



Ceiling Mounted



Ceiling Suspended



Drop Grid



Fully Suspended



Free Standing



Modular



Furniture Attachment

## FEATURES



### WOOL FELT

Non-toxic, non-allergenic, and anti-microbial wool. 100% renewable and cruelty free.



### ACOUSTICAL INSULATION

Outstanding performance in sound absorption.



### ENVIRONMENTAL

100% recyclable, VOC free, non-toxic and non-allergenic.



### TACTILE

100% wool acoustic felt provides soft and luxurious tactile experience.



### FIRE RATED

Class A rating, complies with ASTM E84.



### DURABLE

Impact resistant, will not deteriorate and is non-hygroscopic.

# SOUNDCORE<sup>®</sup> COLORWAYS



**SND213**



**SND108**

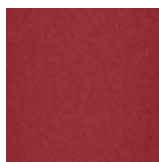

**SND247**



**SND276**



**SND811**



**SND818**



**SND828**



**SND215**



**SND232**

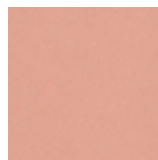

**SND262**



**SND812**



**SND430**



**SND215**

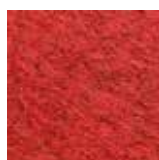

**SND281**



**SND211**



**SND104**



**SND223**



**SND414**



**SND253**



**SND817**



**SND829**



**SND282**



**SND420**



**SND807**



**SND269**



**SND286**



**SND106**



**SND248**



**SND257**

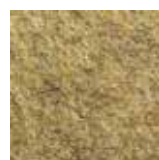

**SND285**

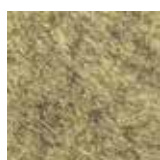

**SND284**

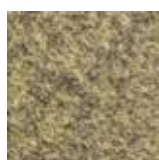

**SND283**



**SND206**



**SND254**



**SND808**



**SND228**



**SND107**

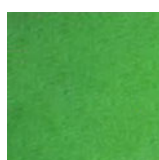

**SND205**



**SND219**



**SND821**

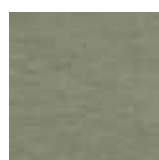

**SND236**



**SND822**



**SND510**



**SND274**



**SND820**



**SND823**



**SND235**



**SND113**



**SND218**



**SND246**



**SND201**



**SND112**



**SND226**



**SND202**



**SND242**



**SND225**



**SND827**



**SND824**



**SND288**



**SND258**



**SND224**



**SND234**



**SND042**



**SND271**



**SND210**



**SND240**



**SND244**



**SND220**



**SND270**



**SND221**



**SND204**



**SND249**



**SND259**



**SND203**



**SND237**



**SND222**



**SND101**



**SND116**



**SND200**



**SND273**



**SND272**



**SND209**



**SND227**



**SND264**





**SND275**



**SND814**



**SND252**



**SND256**



**SND212**



**SND217**



**SND813**



**SND815**



**SND239**



**SND831**



**SND245**



**SND038**



**SND103**



**SND233**



**SND297**



**SND263**



**SND261**



**SND834**



**SND830**



**SND207**



**SND296**



**SND832**



**SND290**



**SND291**



**SND255**



**SND509**



**SND105**



**SND260**



**SND241**



**SND229**



**SND231**



**SND250**



**SND251**



**SND265**



**SND267**



**SND279**



**SND292**



**SND293**



**SND294**



**SND437**



**SND298**



**SND409**



**SND111**



**SND114**



**SND287**



**SND295**



**SND115**



**SND208**



**SND034**



**SND289**



**SND238**



**SND268**



**SND280**



**SND243**



**SND299**



**SND110**



**SND102**



**SND230**



**SND019**



**SND266**



**SND214**



**SND278**

**NEW COLORWAYS**



**SND114**



**SND115**



**SND116**



**SND117**

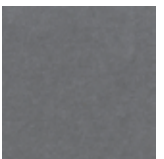

**SND118**



**SND806**



**SND833**

---

◆

# CALL

800-216-7432

# EMAIL

[info@CSISoundcore.com](mailto:info@CSISoundcore.com)

# ADDRESS

9901 W 74th St,  
Minneapolis, MN 55344 USA

---

◆



S

# Fretwell Café, Prebid Attendee List

Company	Contact	E-mail
Momentum Construction	Derek Meachum	<a href="mailto:dmeachum@mvmomentum.com">dmeachum@mvmomentum.com</a>
Feliciana Interiors	Chris Pate	<a href="mailto:chris.pate@felicianagroup.com">chris.pate@felicianagroup.com</a>
Liles Construction	Harris Reeves	<a href="mailto:hreeves@lilesconstruction.com">hreeves@lilesconstruction.com</a>
Yes RECG	Darmel Lee	<a href="mailto:dlee@yesrecg.com">dlee@yesrecg.com</a>
Heartland Contracting, LLC	Mark Fasser	<a href="mailto:mfasser@heartlandnc.com">mfasser@heartlandnc.com</a>
W.C. Construction Company, LLC	Chris Hoover	<a href="mailto:chrish@wcconstructionco.com">chrish@wcconstructionco.com</a>
I. L. Long Construction Co, Inc.	Ken Bell	<a href="mailto:kbell@illong.com">kbell@illong.com</a>
I. L. Long Construction Co, Inc.	Jason Mitchell	<a href="mailto:jmitchell@illong.com">jmitchell@illong.com</a>
Hostetter & Son	Frank Hostetter	<a href="mailto:Frank@hostetterandson.com">Frank@hostetterandson.com</a>
MV Momentum	Derek Meachum	<a href="mailto:dmeachum@mvmomentum.com">dmeachum@mvmomentum.com</a>
Elford Construction	Ben Stickney	<a href="mailto:bstickney@elford.com">bstickney@elford.com</a>
Turner Construction Company	Luke Crawford	<a href="mailto:lcrawford@tcco.com">lcrawford@tcco.com</a>
Turner Construction Company	Sarah Walko	<a href="mailto:swalko@tcco.com">swalko@tcco.com</a>
Schiel Sexton Company, Inc.	Josh Craft	<a href="mailto:jcraft@shielsexton.com">jcraft@shielsexton.com</a>