



UNIVERSITY OF NORTH CAROLINA
CHARLOTTE

APPENDIX

DESIGN GUIDELINES

CLASSROOM PLANNING AND DESIGN

CLASSROOM PLANNING AND DESIGN

1.1 PURPOSE

This section describes the optimal physical design characteristics for 110 classrooms on the UNC Charlotte campus. Classroom renovations in existing buildings should be implemented as closely as possible to the intent stated herein."

1.2 PHYSICAL CHARACTERISTICS

- A. Classroom Types – The “110” category aggregates classroom facilities as an institution-wide resource, even though they may fall under different levels of organizational control. Thus, a “110 Classroom” is a room used for classes not tied to a specific subject or discipline by equipment in the room or the configuration of the room. NC State University 110 classrooms are defined as one of the following:
1. Seminar Room – General-purpose classroom designed for up to twenty students.
 2. Small Classroom – General-purpose classroom designed for a maximum of forty-nine persons inclusive of instructor(s).
 3. Large Classroom – General-purpose classroom designed for fifty to ninety-nine persons inclusive of instructor(s).
 4. Lecture Hall – Large classroom designed for one hundred or more student.
- B. Classroom Location
1. Locate 110 classrooms as close as possible to main entrance levels of buildings.
 2. Locate large-capacity 110 classrooms or lecture halls near the building entrances.
 - a. Classrooms on upper floors of buildings should be located as close to the building stairways and elevators as possible.
 - b. Locate classrooms away from indoor noise-generating equipment and activities, such as toilets and building systems, or away from labs where hazardous materials are used.
 - c. Locate student study / lounge areas near classrooms.
 - d. Provide corridor seating outside the lecture halls and along the hallways outside classrooms.
 - e. Classroom Footprint – The person in the least favored seat should have full visibility to all presented material, i.e. projection screen(s), dry erase marker and/or black boards.
 - f. The ideal configuration of seminar, small and large classrooms is nearly square. A rectangle with a length-to-width ratio of no greater than 1.5 to 1 is acceptable.
 - g. Classrooms that require a media (AV) closet should have a 24 sq. ft. (min) lockable closet.

University of North Carolina at Charlotte Standards and Guidelines
APPENDIX – Design Guidelines Classroom Planning and Design

- C. Classroom Support Closet – Provide at least one lockable storage closet for classroom supplies, maintenance and support equipment, in each classroom building. Closet must have corridor access, be located on the same floor as and be as close as possible to the majority of the classrooms. Minimum size shall be 80 square feet.
- D. Classroom Space Requirements
1. Classroom Seating Capacity – The seating capacity for each new or existing classroom may be calculated by subtracting the required square footage of the Instructor Area and dividing the remaining square footage by the required square feet per chair of the type of seating planned for the space. The following rule-of-thumb square feet per chair amounts include circulation areas, and may be used in preliminary planning for a room.
 - a. Movable tablet-arm seats – 20 square feet per chair
 - b. Fixed seats with folding tablet arms – 17 square feet per chair
 - c. Movable tables and chairs – 24 square feet per chair
 - d. Fixed tables and chairs – 17 square feet per chair
 - e. Upholstered fixed auditorium seats with folding tablet arms – 17 square feet per chair
 - f. Where pedagogical style employs collaborative seating or use of computers, additional space may be required.
 2. Instructor Area – The instructor’s area should be easily visible from all student seating, and provide instructor seating, writing surface, and electronic controls to all audio/visual and lighting systems in the classroom. The following components and guidelines apply to all small classrooms, large classrooms, and lecture halls.
 - a. A minimum 8 feet clear space parallel to the instruction wall (10 feet is preferred) shall be provided in small and large classrooms.
 - b. The instructor’s lectern should be located to one side of the centerline of the instruction wall, and may be adjacent to the sidewall. Placement shall not block students’ views of the instruction wall nor the projection screen(s). A minimum three-foot clearance shall be provided to the front and three feet six inches to the rear of the lectern. Lecterns and smart classroom features shall be located at least 36 inches from the wall and should be fully accessible for faculty or guests with disabilities.
 3. Aisles, Spacing, and Clearances
 - a. Aisles
 - 1) The minimum aisle width in classrooms is 36 inches. Side aisles are preferred in lecture halls. The preferred minimum width for lecture hall aisles is 48 inches.
 - 2) In tiered classrooms and lecture halls, where stepped aisles and ramps are provided, they shall be separated with a half wall or handrail. Tiered lecture halls should have ramps, not stairs, and provide access to multiple levels in large tiered lecture halls to ensure accessibility compliance.
 - b. Spacing and Clearances
 - 1) The ideal viewing angle is no more than forty-five degrees from either side of the center axis of the teaching surface and from the center axis of each

University of North Carolina at Charlotte Standards and Guidelines
APPENDIX – Design Guidelines Classroom Planning and Design

of the projection screen(s). Seating should be placed inside this viewing angle. The projections screen(s) may need to be angled to accommodate ideal viewing angles. Include wheelchair accessible seating in multiple locations (highest and lowest points in the room).

- 2) Minimum spacing between rows of movable tablet-arm chairs perpendicular to the teaching wall is 36 inches. Design classroom aisles with a turn space for wheelchairs.
- 3) Table leg or pedestal spacing shall not interfere with seating.
- 4) Offset rows of seats in rooms with flat or shallow sloped floors, to facilitate an unobstructed view of the instructor area.

E. Room Characteristics

1. Floor Design

- a. Seminar rooms shall have flat floors.
- b. Wood floor construction for risers is not permitted.

2. Doors

- a. The main entry to classrooms should be located at the rear of the classroom.
- b. Doors should be of solid construction for durability and sound control, and operate quietly.
- c. Doors should be equipped with delay action closures, kick plates, and clear glass vision panels or sidelights in accordance with applicable codes. The area of glass in doors should not exceed 100 square inches, with the vision panel base no higher than 42 inches from the floor and top at least 62 inches from the floor. Sidelights should be no wider than 12 inches.
- d. Doors to lecture hall shall open into alcoves and be located at the rear or sides of the classroom.
- e. Doors open out to the corridor but must be located so that they do not block corridor traffic. A recessed entrance may suffice.

3. Wall Construction

- a. Classroom walls shall have a Sound Transmission Class (STC) rating of 50.
- b. Walls separating classrooms from common spaces or restrooms must have an STC rating of at least 53.
- c. Wall separating classrooms from mechanical spaces or other areas with high noise levels must
- d. Extend non-structural partitions including drywall to the building structure above.

4. Windows

- a. Windows are recommended for all 110 classrooms.
- b. Windows should be placed in sidewalls or rear walls and avoided along instructional wall(s).
- c. Windows shall not swing into classroom.
- d. Windows shall have manual fabric shades that pass no more than 3% external light.

5. Ceilings

University of North Carolina at Charlotte Standards and Guidelines
APPENDIX – Design Guidelines Classroom Planning and Design

- a. Ceilings should be a light color, with a minimum reflectance value of 80.
 - b. Minimum ceiling height shall be 9-0 feet AFF for all classrooms. Larger classrooms require proportionally higher ceilings. Rule of thumb for calculating ceiling height AFF:
 - i. Minimum ceiling height in feet at screen = $4' + (\text{Max. View Distance in feet} / 5)$
See Attachment E.
 - c. In classrooms with sloping or stepped floor systems, the ceiling height should be a minimum of 8'-0" AFF at the highest floor elevation.
 - d. 50-60 percent of the area of ceilings shall be acoustical panels.
 - e. The ceiling/floor assembly shall have a minimum sound transmission rating (STC) of 50.
 - f. The exposed grid acoustical ceiling system shall be 24" x 24" and the acoustical tiles shall have a Noise Reduction Coefficient (NRC) of .75 or better.
6. Acoustics - Walls and ceilings should be designed to evenly distribute sound throughout the classroom. The acoustic design must control the sounds and voices in the room so that they are heard easily and accurately. The following rules of thumb should be considered and applied as required in the design of a classroom:
- a. Ambient noise level in classrooms shall not exceed a NC-45 or 35dB. Impact noise levels in classrooms shall be less than 5dB above the ambient level.
 - b. Reverberation time (RT) shall be 0.4-0.6 seconds using the RT-60 method.
 - c. A flutter echo can occur between parallel hard surfaces and shall be avoided. Shape of room (i.e., square vs. rectilinear room) is not as significant, however, floor-ceiling and parallel solid walls are more likely to cause problems. Therefore, the following strategies shall be considered:
 - 1) Parallel walls of large classrooms and lecture halls may require angling.
 - 2) Variations in ceiling height and profile may be required.
 - 3) Floors may need to be sloped.
 - 4) Use acoustically absorbent ceiling material along sides and rear of large classrooms and lecture halls that result in a reverberation time less than 0.6 sec in an unoccupied classroom.
 - 5) A signal to noise ratio (S/N) of +10dB minimum is required (average hearing) +15dB is preferred (accessible for hearing impairment).
- F. Interior Finishes - Interior finishes for classrooms should be durable, easy to clean and repair. Finishes should be selected to avoid visual distraction. Avoid glossy finishes and very busy patterns. (See also Section 2 - Division 9 - Finishes)
1. Wall coverings
 - a. Color selection for a teaching wall with a whiteboard should contrast from adjacent neutral walls.
 - b. Provide acoustical wall panels where required.
 2. Flooring - A variety of finishes is acceptable in classrooms. Durability, maintenance and life-cycle cost analysis should guide the selection of the appropriate materials.

University of North Carolina at Charlotte Standards and Guidelines
APPENDIX – Design Guidelines Classroom Planning and Design

- a. Carpet for classrooms should be commercial/institutional grade continuous-filament type 6,6 nylon, 100% solution dyed, tufted or fusion bonded level loop, anti-static, U.L. Class A.
 - b. Carpet shall have a lifetime warranty against edge raveling and delamination. Seams should not have to be sealed during the installation process. Chair pads shall not be required.
 - c. Carpet Wear: No more than 10% by weight of pile face fiber during the lifetime of the carpet.
 - d. Color and pattern shall be selected to help conceal dirt and stains. Carpet shall have 10-year warranty against fading.
 - e. An aluminum nosing strip mechanically fastened with a reflective strip is required on treads in tiered classrooms.
 - f. Resilient flooring should be commercial/institutional grade, with slight variegations that help conceal dirt and stains.
 - g. Other flooring materials, such as wood, or tile, should receive sealer. Painted concrete is unacceptable.
3. Wall Base
- a. Minimum 4” high rubber cove base is typical.
 - b. If wood is chosen for historic renovations, materials matching existing should be chosen.
4. Chair Rail [or Fiberglass Reinforced Plastic (FRP)]
- a. Classrooms with movable furniture shall receive a simple profile chair rail sufficient to protect walls from contact with sides and backs of tables, chairs, or desks.
 - b. Install chair rail at 25” to 33” above the floor. Verify mounting height and width with furniture specified.
 - c. Chair rail is not required on a teaching wall where it may interfere with mounting height requirements for dry erase marker boards.
5. Window Treatments
- a. Window Treatments shall be provided at all windows, exterior and interior.
 - b. All windows shall receive as a minimum:
 - 1) Manually controlled fabric shades that pass no greater than 3% of ambient lighting (5% for south and west elevations exposed to sun).
 - 2) For powered shades, provide low voltage systems and include low voltage shade interface that can be controlled from lectern.
 - c. Blackout shades shall only be installed where appropriate for the teaching needs of the College or department. Blackout shades shall be installed with light-blocking channels or must overlap the window opening to prevent light leakage.

1.3 Classroom Furnishings

A. Instructor Lecterns

Standardized lecterns will be used campus-wide, and specified to match the level of technology planned for the specific classroom. The typical lectern serves as both the instructor’s desk and a locking cabinet for instructional technology components.

University of North Carolina at Charlotte Standards and Guidelines
APPENDIX – Design Guidelines Classroom Planning and Design

1. All lecterns shall be accessible, properly vented, provide for rack mounted AV equipment, security and accessible control panels.
 2. All lecterns shall be ADA compliant.
- B. Student Seating and Writing Surface
1. Seating types that may be considered include, but are not limited to the following:
 - a. Movable tablet-arm chairs
 - b. Fixed seats with folding or fixed tablet arms
 - c. Movable tables and chairs
 - d. Fixed tables and chairs
 - e. Fixed auditorium seats with folding tablet arms
 2. Seating Specifications
 - a. Writing surfaces shall be durable, with a smooth, non-glare surface.
 - b. Auditorium style seats shall have a seat width of 22"-24".
 - c. Seats at table assemblies shall have a minimum seat width of 19".
 - d. Tablet-arms should be large or oversized (212 square inches minimum).
 - e. Tables should be sturdy, 18 - 24" deep units with a flat PVC or wood edge banding. The minimum table width for each student is 30 linear inches. Fixed tables must be anchored solidly to the floor system. Fixed classroom desks should meet ADA standards for height and leg space to maximize utilization (height: top 28 inches from finished floor with 27 inches of knee room) and should be adjustable. Insure that 36" clear behind table is maintained for access.
 - f. Accessible tables shall be adjustable.
 - g. Upholstered furnishings shall have heavy-duty stain repellent (e.g.: crypton, nanotex finish) fabric that meets or exceeds 80,000 double-rubs, per the Wyzenbeck method).
 - h. Ten percent of all seating must be suitable for left-handed use.
- C. Fixed Equipment - The following Items are required in all 110 classrooms:
1. Writing Surfaces - Writing surfaces (dry erase marker or chalk boards) shall be provided in all classrooms. Dry erase marker boards are preferred. All boards shall have the following minimum characteristics:
 - a. All boards shall be minimum 48" in height.
 - b. Boards shall extend across entire width of wall in instructor area and along side and rear walls for student use.
 - c. All boards shall be mounted with the top of the marker or chalk tray at 34" AFF.
 - d. Position board so vertical seam appearance is symmetrical. All seams or joints in board sections (if required) shall have no gap or are to be covered with a low profile spline connection of matching board.
 - e. Board shall be equipped with full-length, rounded end marker/chalk tray with open ends. There shall be no sharp edges or corners on tray.
 - f. Boards may slide vertically or horizontally.
 - g. Specific requirements relating to board type

University of North Carolina at Charlotte Standards and Guidelines
APPENDIX – Design Guidelines Classroom Planning and Design

- h. Dry Erase Marker Boards
 - 1) Dry erase marker boards shall have a low-gloss white or off-white finish, and a minimum 50-year warranty.
 - 2) Dry erase marker boards shall be made of a balanced construction consisting of a “P3 ceramic steel” surface composed of porcelain enamel on 28-gauge steel bonded to a minimum ½” thick MDF core with an aluminum back. Bonding material shall be waterproof.
 - 3) Board shall have heavy-duty aluminum trim, with all necessary mounting hardware for installation provided. Boards shall be mechanically fastened in place and no glue shall be allowed.
- i. Chalkboards
 - 1) Chalkboards shall have a black surface and have a 50-year warranty against “polishing”.
 - 2) Provide at least one dry marker board in the classroom.
- 2. Projection Screens - Each classroom shall be equipped with one or more projection screens positioned to maximize simultaneous use with board while providing optimal viewing angles. Exceptions to the specifications below shall be approved by Classroom Support Services.
 - a. Minimum specifications
 - 1) Screens shall be seamless.
 - 2) Matte white finish.
 - 3) Screen gain shall be between 1 and 1.5.
 - 4) Glass bead or similar screen surface treatments shall not be used.
 - 5) Screens 8ft wide and larger shall be tab tensioned.
 - 6) Screen surface should be easily cleanable with soap and water.
 - b. Size
 - 1) Screen image height should follow the viewing distance formula of 1/5 the distance from the farthest or least favored viewer.
 - 2) The necessary screen height should be taken into consideration when planning ceiling heights.
 - 3) Screen aspect width-to-height ratio shall be 16:10.
 - 4) See Attachment E for recommended screen size matrix.
 - c. Mounting Location
 - 1) Bottom of viewable area shall be no lower than 48” AFF.
 - 2) Mount all screens to allow clearance between the screen and dry erase marker/chalk trays.
 - 3) A minimum of six linear feet of writable surface shall remain visible in the instructor area when the screen or screens are in use.
 - 4) All viewers shall fall within 45 degrees to either side of perpendicular from the center of the screen, forming a 90-degree viewing angle.
 - 5) See Attachment B for additional information.
 - d. Motorized Screens

University of North Carolina at Charlotte Standards and Guidelines
APPENDIX – Design Guidelines Classroom Planning and Design

- 1) All screens eight feet or more in width shall be motorized unless they are to remain open (i.e., fixed-frame screens).
- 2) Low voltage controls shall be provided with all motorized screens. If not integrated into projection screen housing, the low voltage control box shall be located next to the screen motor above the ceiling in an accessible location for integration with the A/V control system.
- 3) Provide a manual low-voltage wall-mounted switch that operates independently from the A/V control system. Locate the switch adjacent to the instructor area and outside of the screen hanging area.
- 4) Key operated switches are not allowed.
- 5) Motorized screens should not have trap doors.

1.4 MECHANICAL AND ELECTRICAL SYSTEMS

A. Mechanical (HVAC) systems

1. Air Distribution

- a. Mechanical systems supporting classrooms should generate a background noise of no more than NC 20-25 at diffusers.
- b. Locate supply air outlets and return air intakes away from lecterns and fixed microphones.
- c. There should be no air discharged onto projection screens.
- d. The preferred arrangement of supply air outlets is toward the front of the classroom, with return air intakes at the rear of the classroom.
- e. Where required, the media (AV) closet should also have supply air and proper venting.

2. Electrical and Instructional Technology Systems Infrastructure - The electrical items enumerated in this document do not include specifics for all equipment that may be included since those requirements will vary according to which equipment is chosen for a given space and in Attachment C, AV Conduit Riser Diagram. Additional infrastructure may be required to meet the functional needs of the classroom.

- a. Provide 120-volt branch circuit power for all classroom instructional technology system components.
- b. All conduit and electrical circuits shall have the same ground reference. It is preferable to have two separate grounds, one for telecommunications and one for the building.
- c. All audio, video, and control electrical circuits should be fed from “clean legs” from the transformer, free of high inductive loads. There must be NO elevator motors, compressor motors, blower motors, etc., on the side of the power transformer that feeds media equipment.
- d. Dedicated power circuit(s) for technology system infrastructure shall be on same phase for each classroom.
- e. Minimum of one duplex outlet every 48” on all classroom walls excepting where

University of North Carolina at Charlotte Standards and Guidelines
APPENDIX – Design Guidelines Classroom Planning and Design

there is an instructor wall. Where there is an instructor wall, there should be a minimum of three duplex outlets, with one of those being center of the instructor wall.

- f. One quadruplex outlets on a dedicated circuit for the teaching lectern.
 - g. One duplex outlet on its own dedicated circuit at the ceiling-mounted projector on same phase as the teaching lectern.
 - h. Other outlets for ceiling mounted equipment whose cabling comes from above the ceiling and terminates below the ceiling should be cut into the ceiling tile and mounted on the same tile as the equipment.
 - i. Where motorized projection screen(s) are required, provide 120-volt power to an accessible junction box above the ceiling adjacent to the screen(s) and low voltage control interface(s). Connect power to the electric screen(s) via flex conduit. Provide cut off switch for screen.
 - j. If motorized shades are specified, provide 120-volt power to an accessible junction box above the ceiling to tie in with the shades and low voltage control interface.
3. Empty Conduits and Junction Boxes
- a. Provide an accessible AV junction box above the ceiling (preferred), in the wall, or in a closet in each classroom. Box shall be sized appropriately for the number of conduits being used.
 - b. Route one empty 1 1/4" conduit with pull string from each projector location to the AV box.
 - c. Provide a minimum of one 1 1/4" conduit from the AV box to the lectern.
 - d. Provide junction boxes above each location for speakers in the ceiling. Link the junction boxes with a 3/4" conduit with pull string and then link to the AV box.
 - e. If using motorized projection screen(s), route one 3/4" conduit with pull string from the low voltage control to the AV junction box.
 - f. If motorized shades are used in the room, route one 3/4" conduit with pull string from the low voltage control interface to the AV junction box.
4. Telecommunications Outlets
- a. Provide a minimum of one duplex network drop for the teaching lectern either in a floor box or on the teaching wall at the lectern location.
 - b. In large classrooms and lecture halls, additional telecommunication outlets may be required at back of room, at accessible student seating areas, or for wireless access points.
 - c. Refer to UNC Charlotte Design and Construction Manual, Section 2, Division 27 for ITS Telecommunications Standards.
5. Classroom Lighting
- a. All 110 classrooms shall be designed to meet a minimum of 350 lux of dimmable general room lighting at the working surfaces. Light readings in excess of 500 lux at the working surface will be considered excessive and may require correction.
 - b. Lighting design shall be zoned to allow for different light levels to be used simultaneously at the instructor's area and student seating with neither spilling onto the projection screen.

University of North Carolina at Charlotte Standards and Guidelines
APPENDIX – Design Guidelines Classroom Planning and Design

- c. Provide either dimmable parabolic lay-in or pendant mounted direct-indirect fixtures for general lighting applications.
 - d. Coordinate any pendant fixtures with ceiling mounted equipment and all projection paths. Section drawings including elevations are required for all pendant fixtures.
 - e. Wall switches must be easy to use and labeled to indicate lighting zone or preset.
 - f. Locate 3-way switches at entry door(s) to each classroom and provide additional switches at the instructor wall or lighting controls at the lectern.
 - g. Occupancy sensor technology shall be used in lecture halls.
6. Classroom Lighting Controls
- a. For rooms of capacity 80 or greater, provide a low voltage, dimmable, programmable lighting control system. The system shall accommodate a minimum of 3 scenes.
 - b. The lighting control system must support RS 232 or TCP/IP connectivity for remote management of classroom lighting.
 - c. The master lighting control units should not be accessible to users.
 - d. Locate lighting control system dimmer modules, boosters, etc. above accessible ceiling at the lighting zone served.

1.5 Instructional Technology

- A. Overview - Classroom design should accommodate current pedagogies and technologies while at the same time provide the opportunity for new techniques to be incorporated in the future. To help accomplish this goal, all new or renovated classroom facilities at UNC Charlotte will receive an infrastructure package based on the description provided herein and the AV Conduit Riser Diagram in Attachments C & D. This infrastructure must be laid out specifically for each space that requires or may require AV technology.
- B. The technology included in each classroom will be determined by UNC Charlotte.

University of North Carolina at Charlotte Standards and Guidelines
APPENDIX – Design Guidelines Classroom Planning and Design

Attachment A

Classroom Layout Diagram

This diagram illustrates typical spacing, view angles and design issues to be considered.

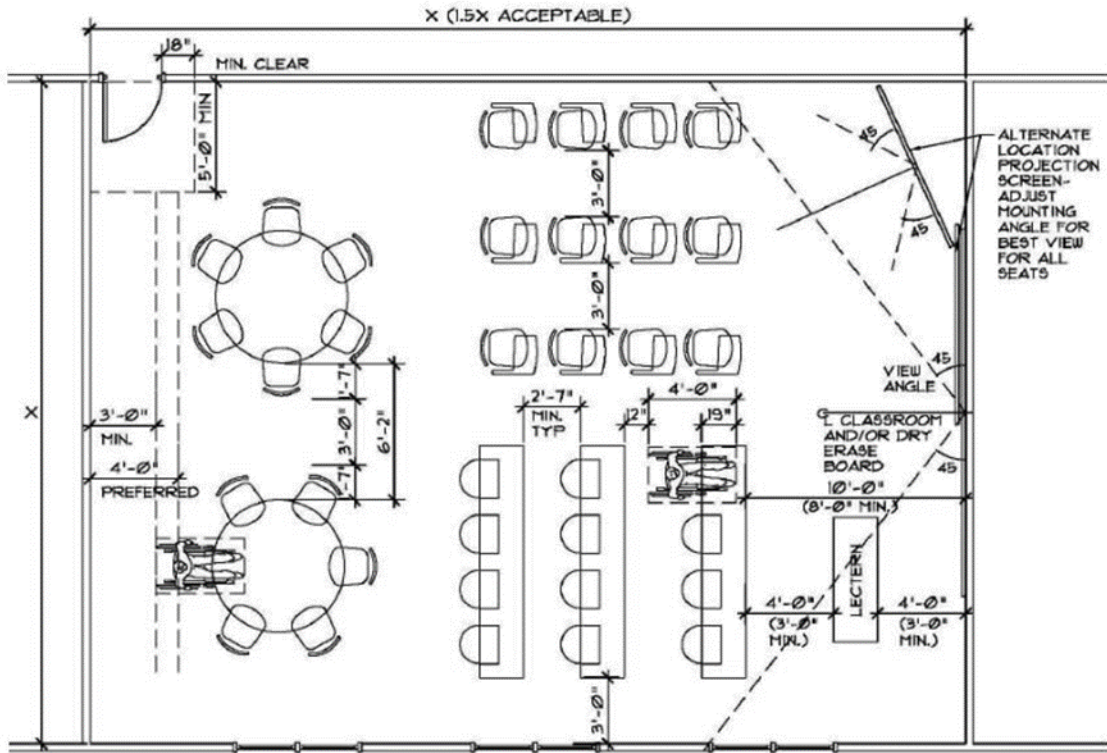

CLASSROOM DIAGRAM
NO SCALE

THIS DRAWING INTENDED TO ILLUSTRATE VARIOUS CLASSROOM REQUIREMENTS, SPACING AND AISLE SIZES ETC. DRAWING FOR REFERENCE ONLY.

DIFFERENT SEATING STYLES SHALL NOT BE MIXED IN CLASSROOMS.

NOTE: AISLE FOR FIXED TABLES MAY BE LOCATED AT THE SIDE OR CENTER OF THE CLASSROOM

COLLABORATIVE/COMPUTER TEACHING METHODS MAY REQUIRE GROUP/FLEXIBLE SEATING ARRANGEMENTS. ADDITIONAL SPACE MAY BE REQUIRED TO ACCODATE CAPACITY AND REQUIRED AISLE SPACING ETC.

VIEW ANGLES FOR ALL DRY ERASE/BLACK BOARDS, PROJECTIONS SCREENS SHOULD BE CONSIDERED WHEN SELECTING SEAT LAYOUT AND SELECTION

TABLET ARM CHAIRS 

FIXED TABLES AND MOVEABLE CHAIRS 

University of North Carolina at Charlotte Standards and Guidelines
APPENDIX – Design Guidelines Classroom Planning and Design

Attachment B

Classroom Section

This diagram illustrates typical layout and design issues to be considered.

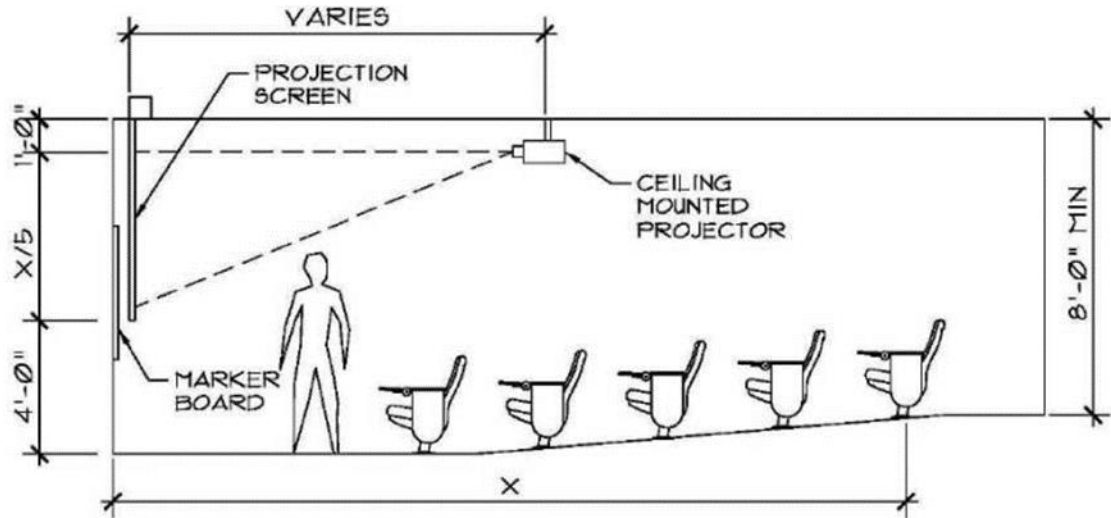

University of North Carolina at Charlotte Standards and Guidelines
APPENDIX – Design Guidelines Classroom Planning and Design

Attachment C

Typical Riser

These diagrams illustrate typical A/V conduit layout and design issues to be considered.

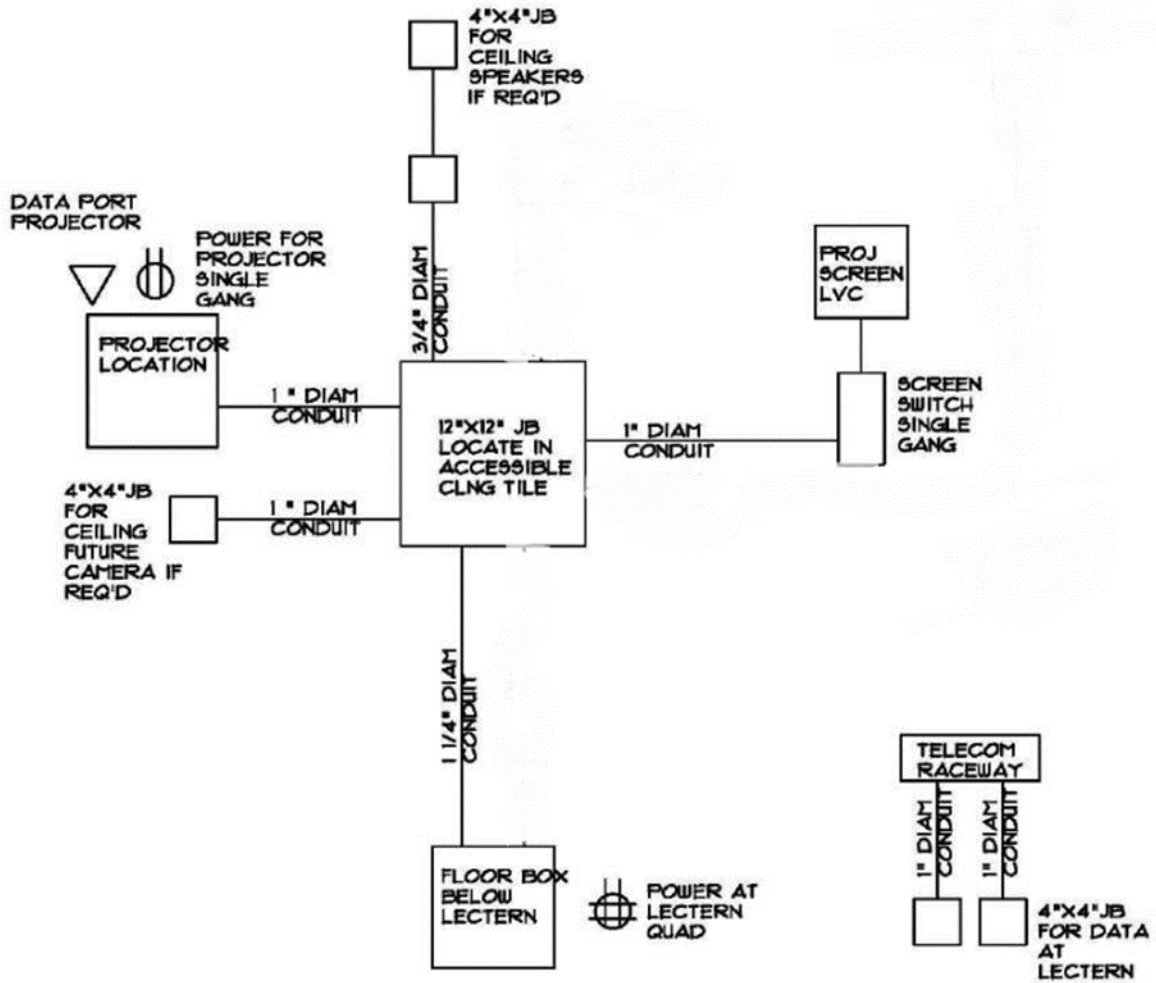

TYP RISER

University of North Carolina at Charlotte Standards and Guidelines
APPENDIX – Design Guidelines Classroom Planning and Design

Attachment D

These diagrams illustrate typical A/V conduit layout and design issues to be considered.

Riser with Interactive Board and/or Flat Panel Display

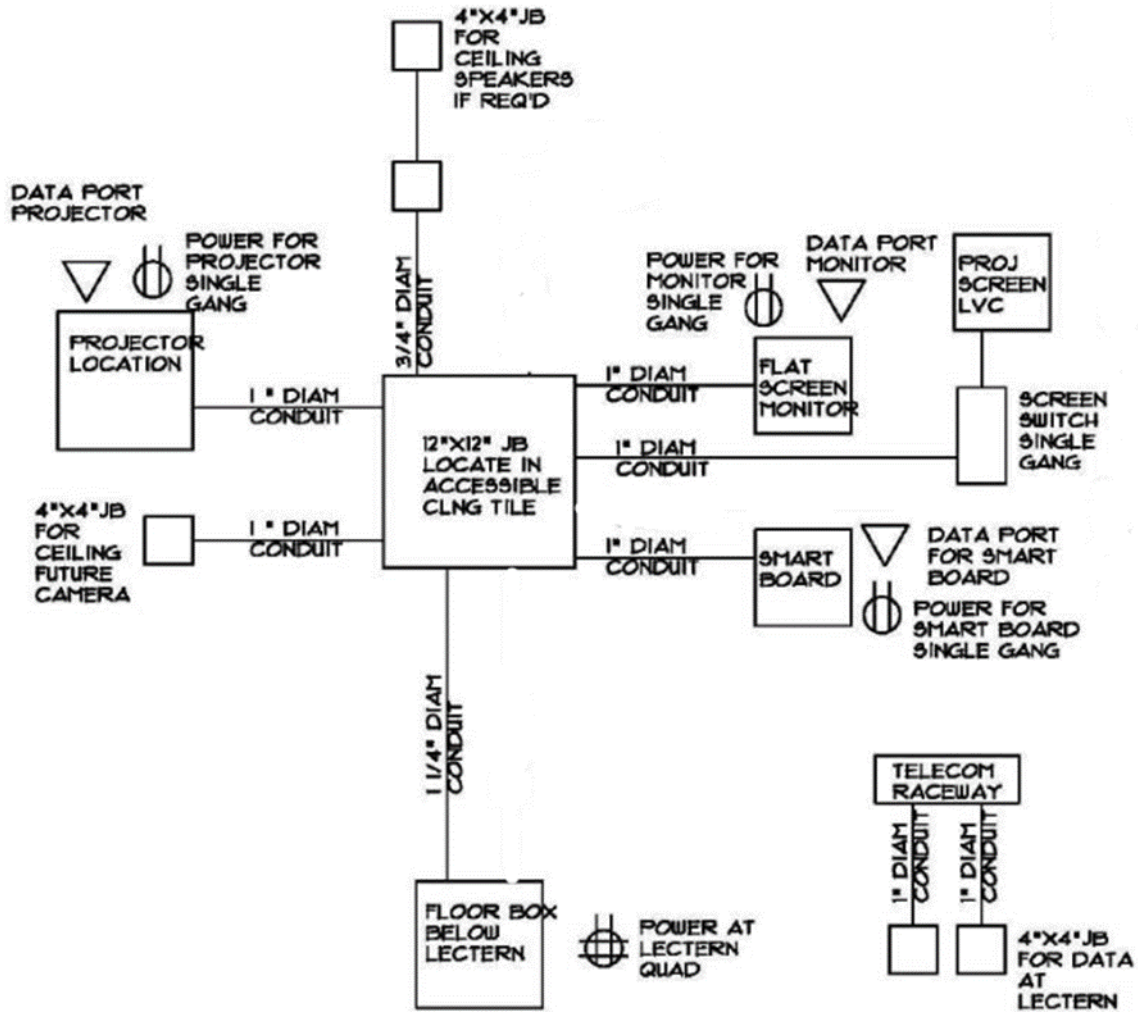

RISER WITH SMART BOARD & FLAT SCREEN

University of North Carolina at Charlotte Standards and Guidelines
APPENDIX – Design Guidelines Classroom Planning and Design

Attachment E

Screen Size Matrix

Least Favored Viewer	Minimum Image Height	16:9 Image Width	Screen Diagonal	Minimum Ceiling Height at Screen	Minimum Distance to Front Row Seat
10'	2'	3.56'	4.08'	6'	4'
15'	3'	5.33'	6.12'	7'	6'
20'	4'	7.11'	8.16'	8'	8'
25'	5'	8.89'	10.20'	9'	10'
30'	6'	10.67'	12.24'	10'	12'
35'	7'	12.44'	14.28'	11'	14'
40'	8'	14.22'	16.32'	12'	16'
45'	9'	16.00'	18.36'	13'	18'
50'	10'	17.78'	20.40'	14'	20'
55'	11'	19.56'	22.44'	15'	22'
60'	12'	21.33'	24.48'	16'	24'
65'	13'	23.11'	26.52'	17'	26'
70'	14'	24.89'	28.56'	18'	28'
75'	15'	26.67'	30.60'	19'	30'
80'	16'	28.44'	32.64'	20'	32'
85'	17'	30.22'	34.68'	21'	34'
90'	18'	32.00'	36.72'	22'	36'
95'	19'	33.78'	38.75'	23'	38'

University of North Carolina at Charlotte Standards and Guidelines
APPENDIX – Design Guidelines Classroom Planning and Design

Glossary

NC: Noise Criteria - noise levels at in each octave band that is plotted and compared to established NC curve.

NCIH: North Carolina Information Highway

NRC: Measure of absorption or ability of a material to absorb sound

NR: Noise Reduction: % sound that passes through a wall/ceiling to an adjacent room.

RT: The amount of time used to determine sound decay - measured in Sabines using the RT-60 method of calculation. The RT of a space can be described as

- Lively where sound decay is long--e.g. Cathedral/Auditorium.
- Dead where the sound is absorbed quickly--e.g.: recording studio/bedroom.

RT- 60: RT60 the measurement of time it takes a signal to fall -60db. A sample calculator can be found at: www.trinitysoundcompany.com/rt60.html

STC: Sound Transmission Class: Single number that describes the average loss of transmitted sound through a partition/barrier (the higher the number the less transmission of noise).

S/N or SNR: Signal to Noise Ratio: Ratio that describes the intelligibility of the spoken word in a space compared to the ambient sound levels.

Screen Gain: A measurement of the reflectivity of any screen or projection surface. The gain number represents a ratio of the light that is reflected from the screen, when as compared to the light reflected from a standard white (magnesium oxide) board. A screen with a gain of 1.0 will reflect the same amount of light as that from a white board. A screen rated at 1.5 gain will reflect 50% more light as that from a white board, Screen gain measurements are taken from the brightest, generally center perpendicular to the screen. Gain drops off as you move to either side of the center.



UNIVERSITY OF NORTH CAROLINA
CHARLOTTE